

K597

Fitting Kit

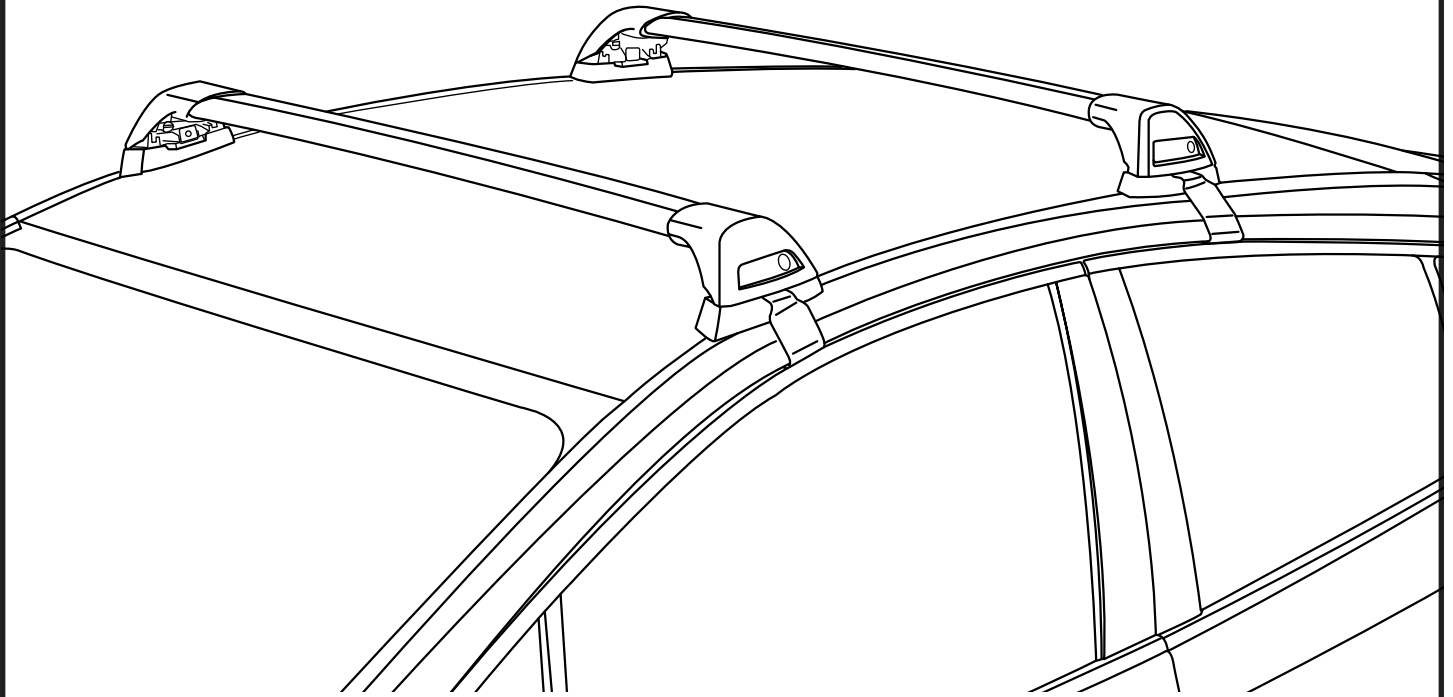

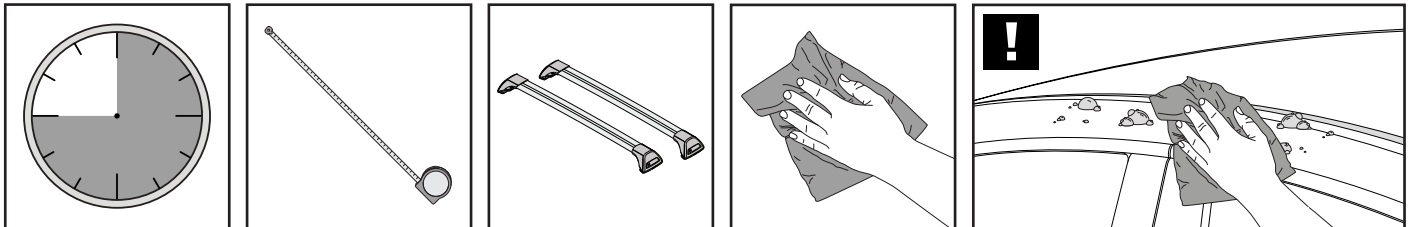



REQUIRED • OBLIGATOIRE • REQUERIDOS • ERFORDERLICH • RICHIESTO • 需要 • ОБЯЗАТЕЛЬНО

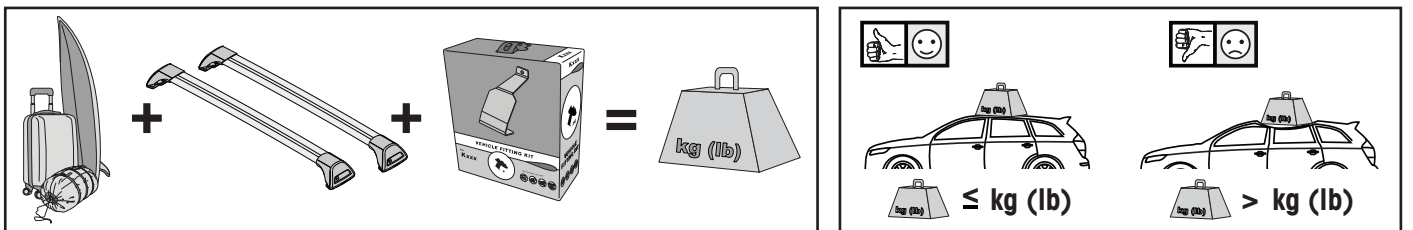

MAXIMUM kg (lb) • MAXIMAL kg • MASSIMO kg • MÁXIMO kg • 最大 kg • МАКСИМУМ kg

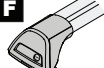
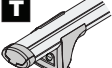

		F  T  P 	HD 
Nissan Micra, 5dr Hatch 10 - Jan 15	CN	50 kg (110 lb)	50 kg (110 lb)
Nissan Micra K13, 5dr Hatch 10 - Jan 15	AU, NZ, ZA, EU	50 kg (110 lb)	50 kg (110 lb)
Nissan Micra K13, 5dr Hatch 15 +	AU, NZ, ZA, EU	50 kg (110 lb)	50 kg (110 lb)

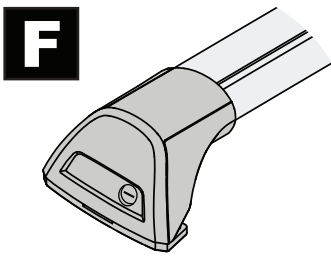
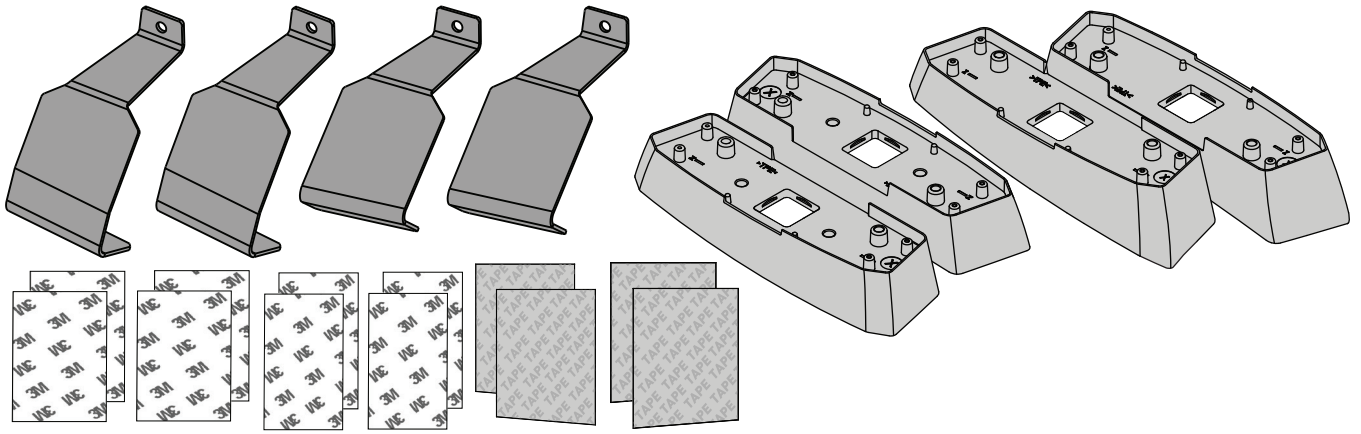

F
FLUSH BAR (F)

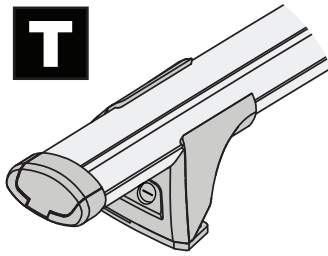

T
THROUGH BAR (T)

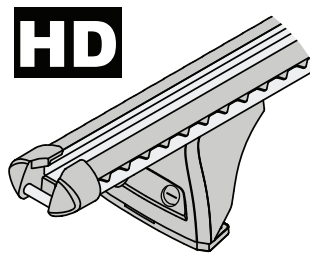

HD
HEAVY DUTY BAR (HD)

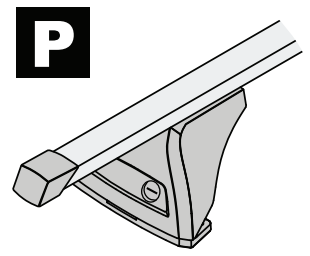

P
P BAR (P)

ATTENTION • ATENCIÓN • AUFMERKSAMKEIT • ATTENZIONE • ATENÇÃO • 注意 • ВНИМАНИЕ

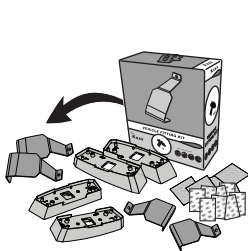

K597
= 0.92 kg (2 lb)

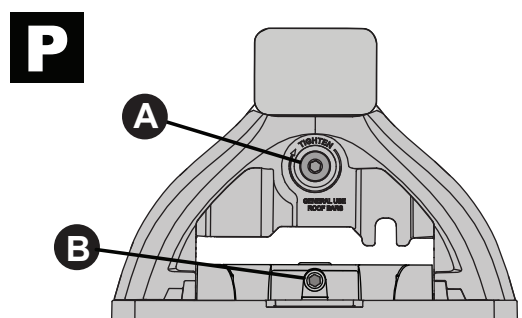
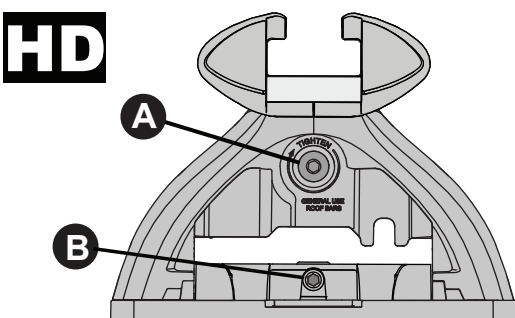
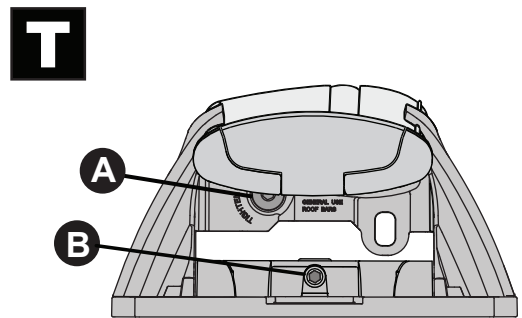
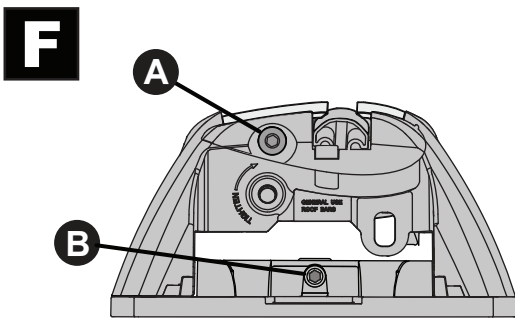
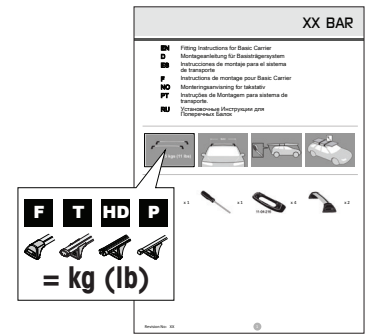
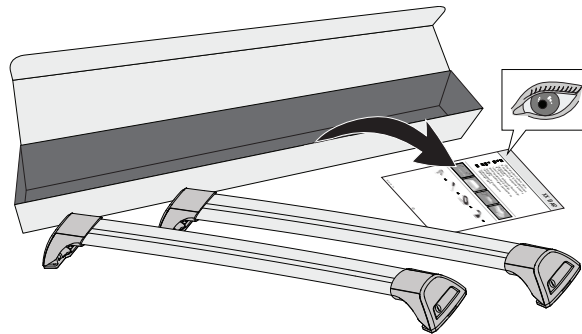

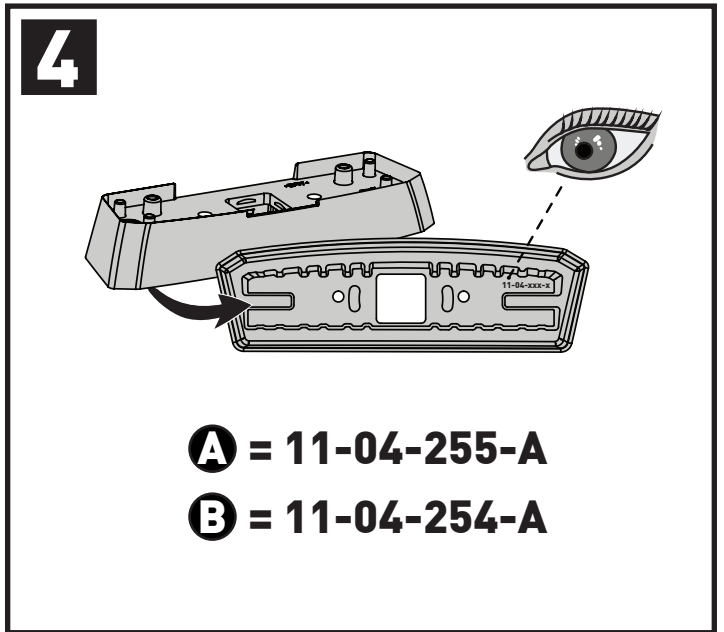
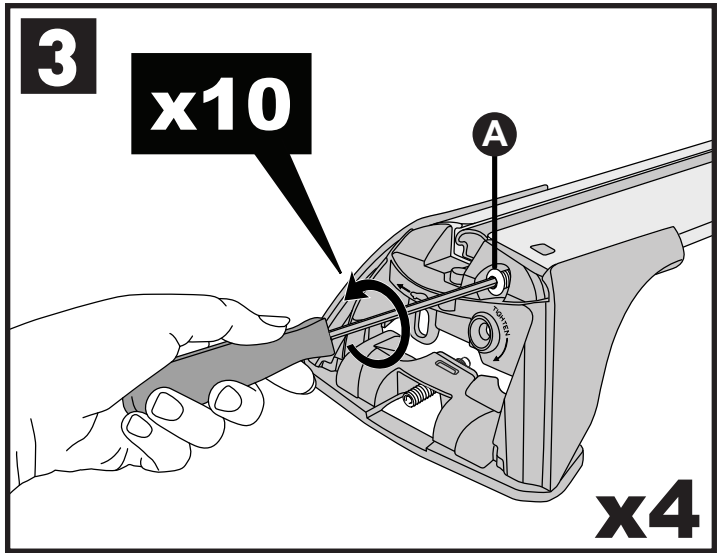
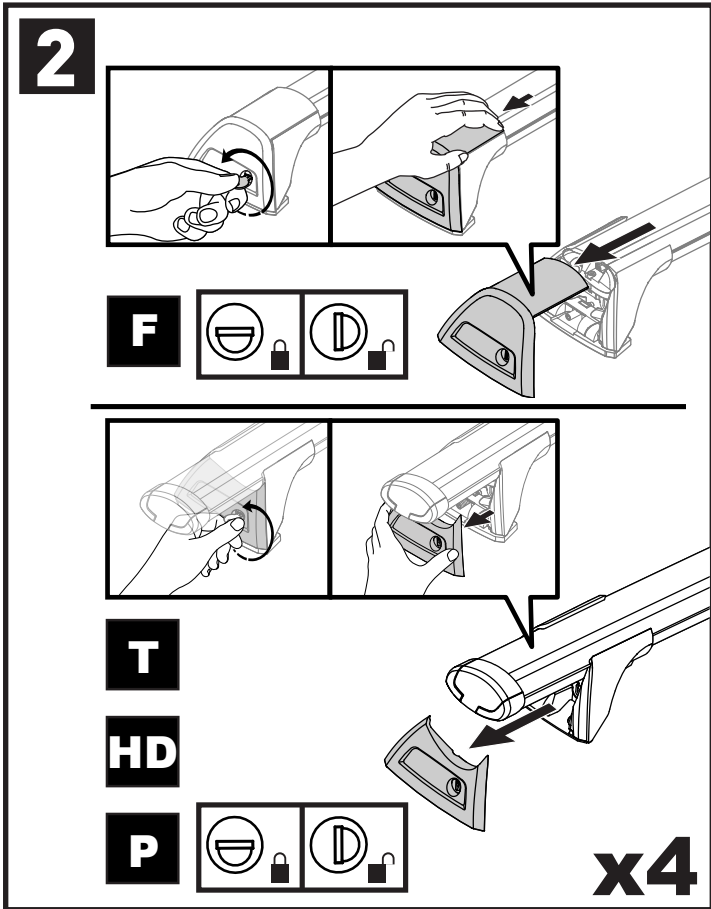
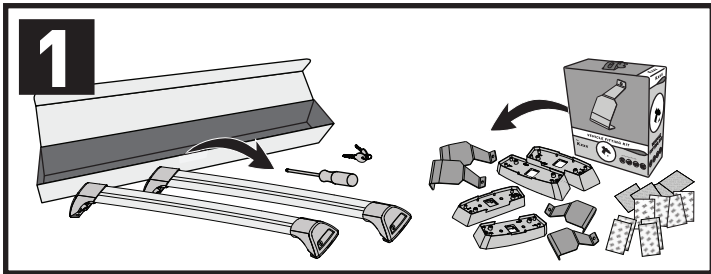

PLACEMENT • MONTAGE • COLOCACIÓN • PLATZIERUNG • COLLOCAMENTO • COLOCAÇÃO • 位置 • РАЗМЕЩЕНИЕ

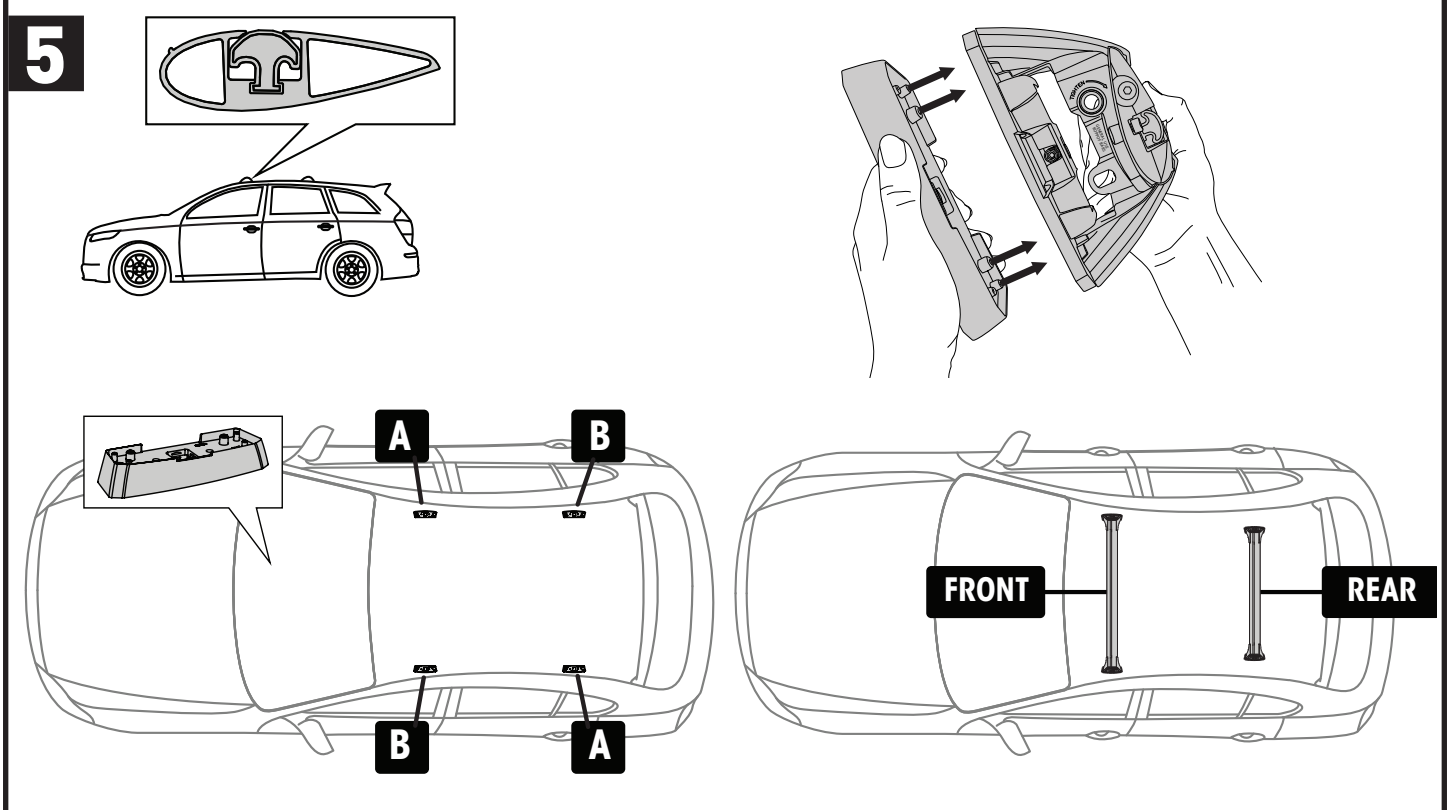

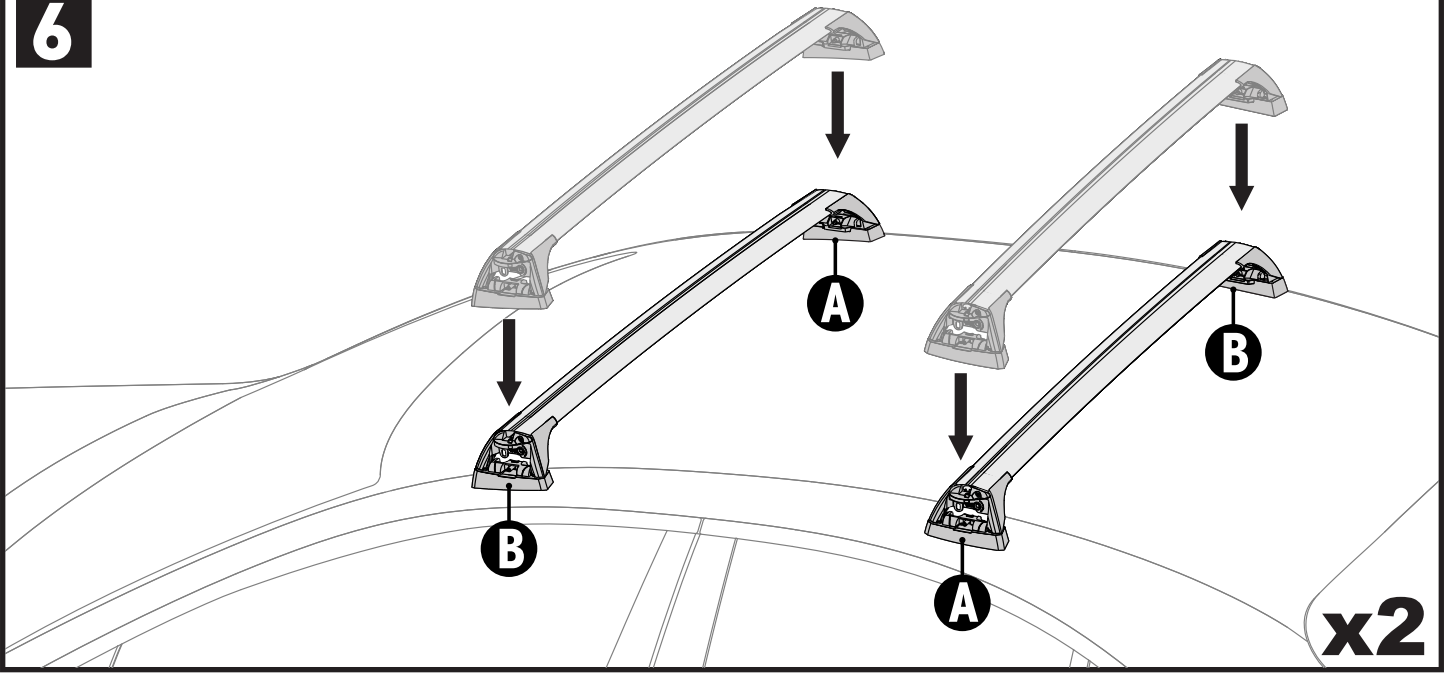
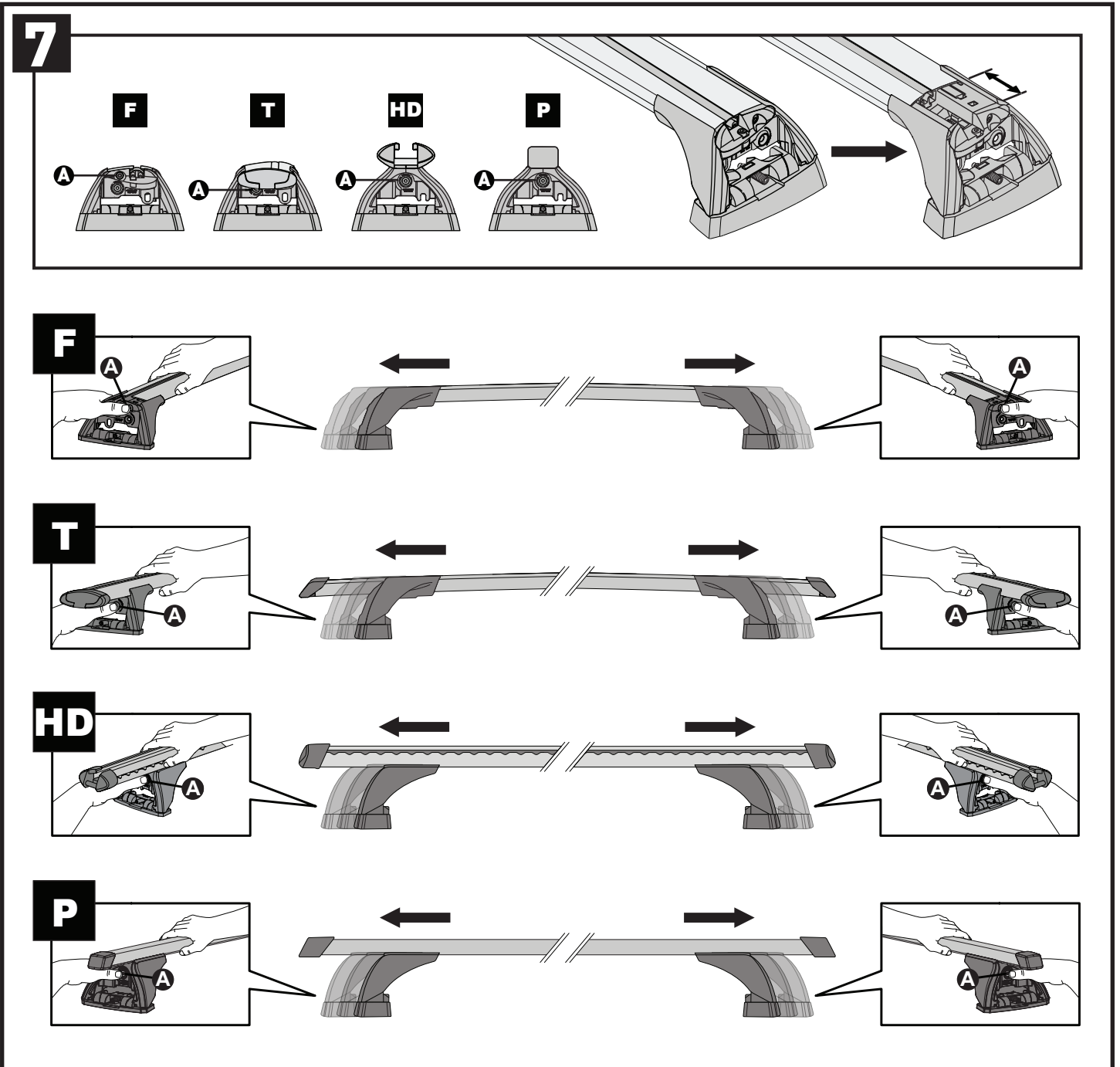

6**7**

8

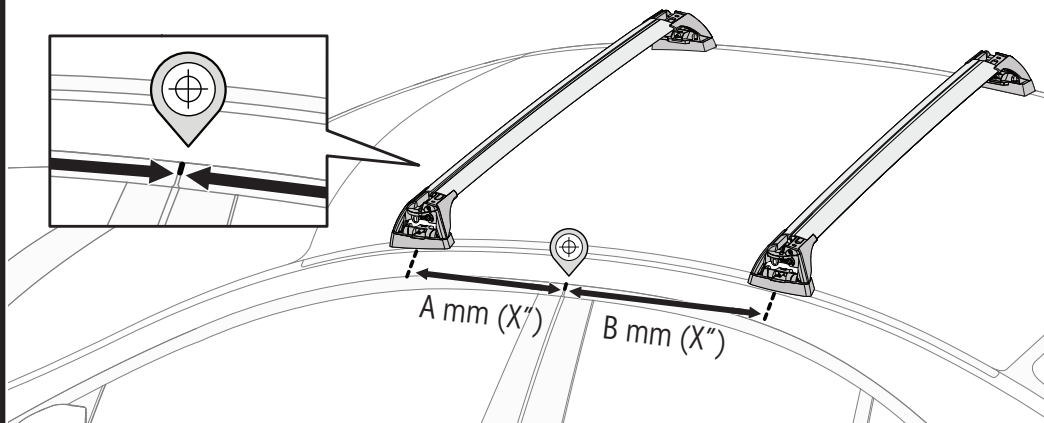
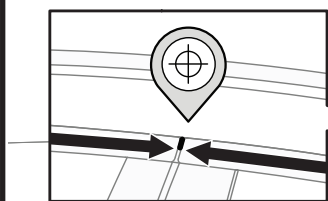
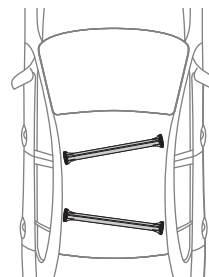
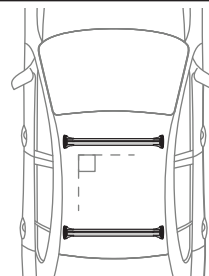
mm / inches 



		A	B
Nissan Micra, 5dr Hatch 10 - Jan 15	CN	230 mm (9")	370 mm (14 5/8")
Nissan Micra K13, 5dr Hatch 10 - Jan 15	AU, NZ, ZA, EU	230 mm (9")	370 mm (14 5/8")
Nissan Micra K13, 5dr Hatch 15 +	AU, NZ, ZA, EU	230 mm (9")	370 mm (14 5/8")

PLACEMENT • MONTAGE • COLOCACIÓN • PLATZIERUNG • COLLOCAMENTO • COLOCAÇÃO • 位置 • РАЗМЕЩЕНИЕ

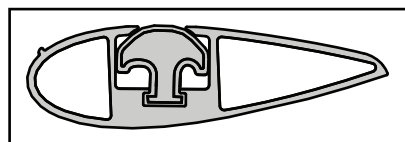
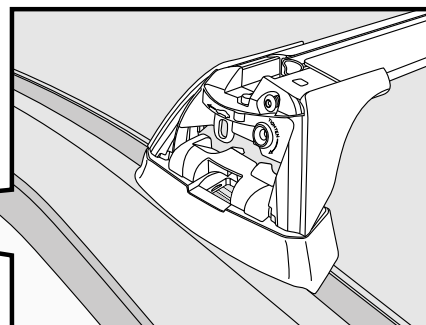
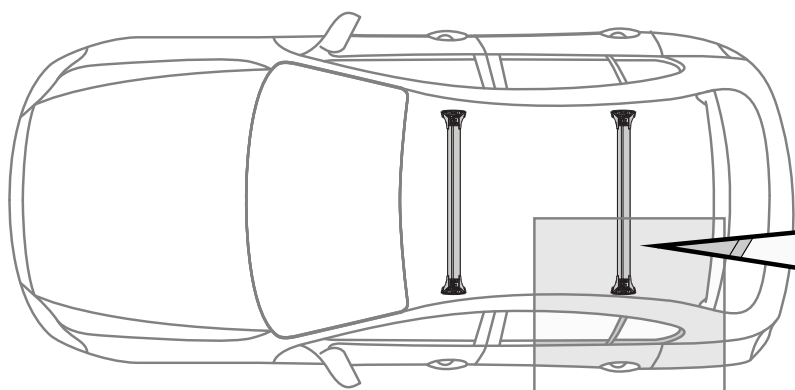

9

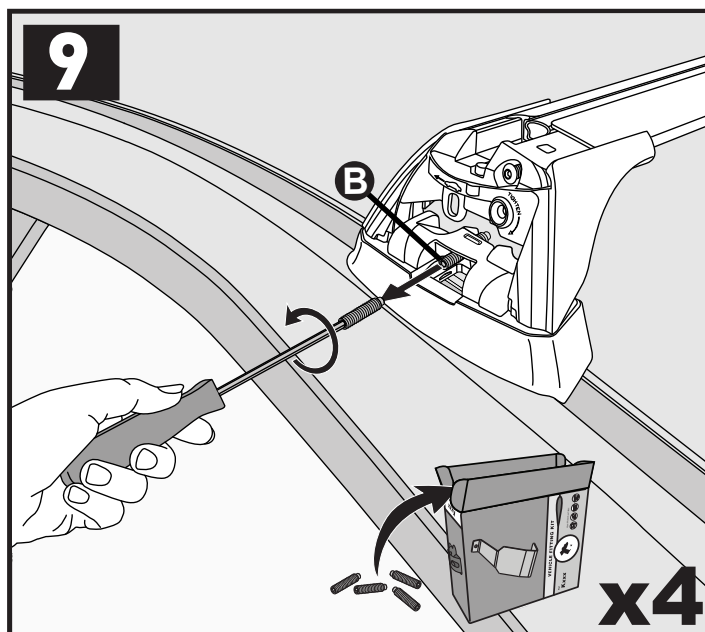

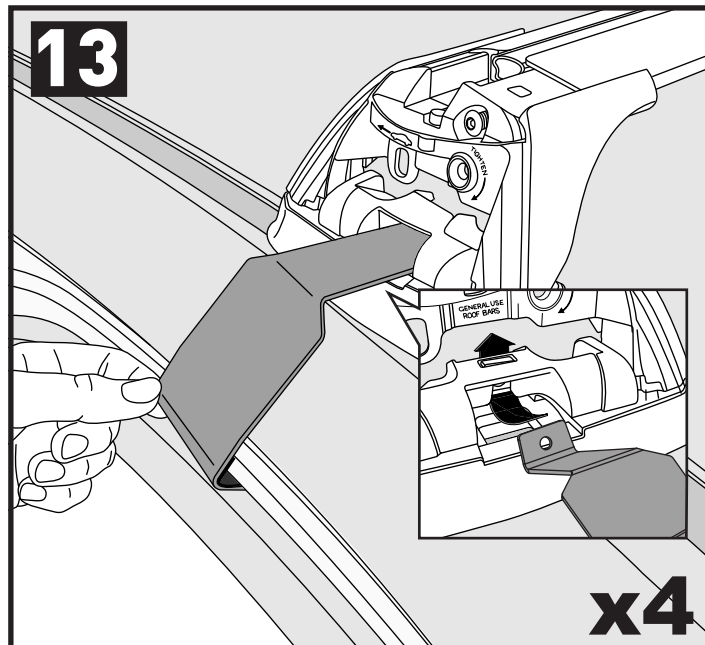
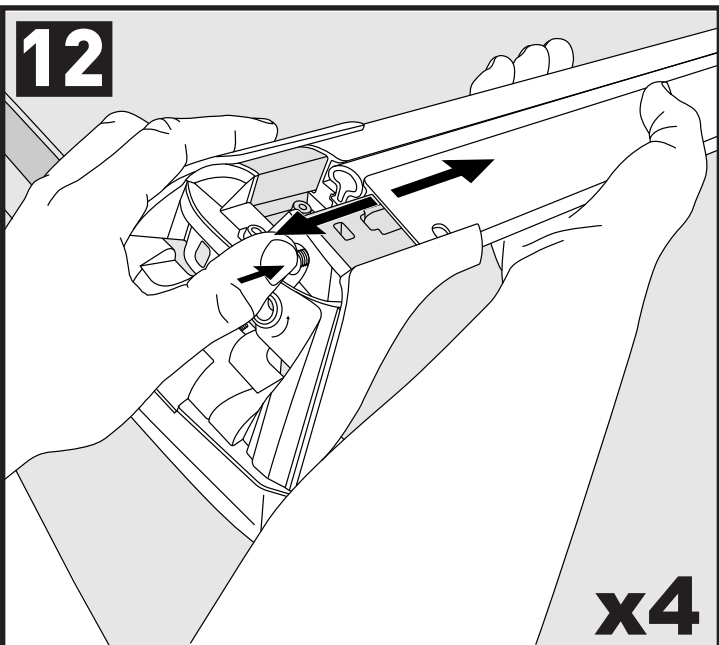
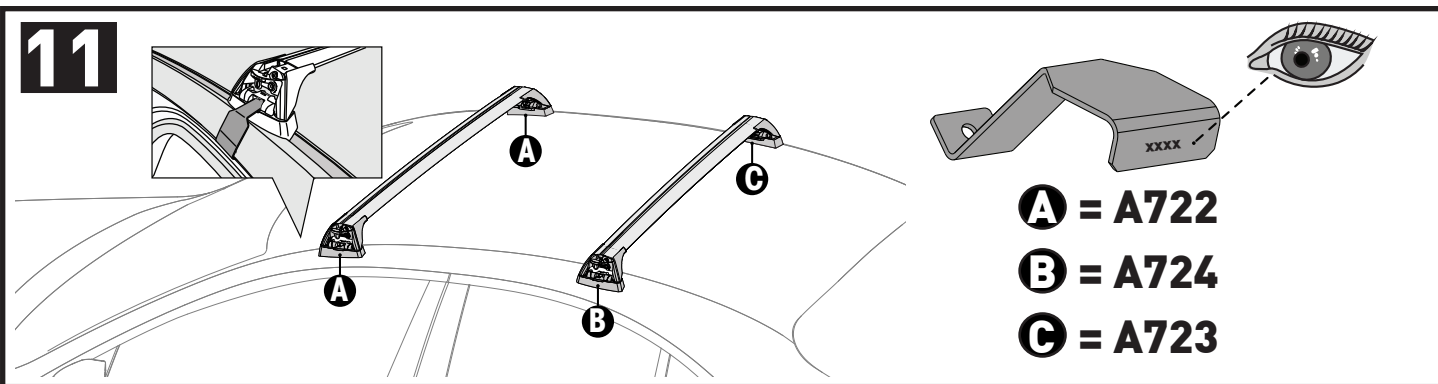
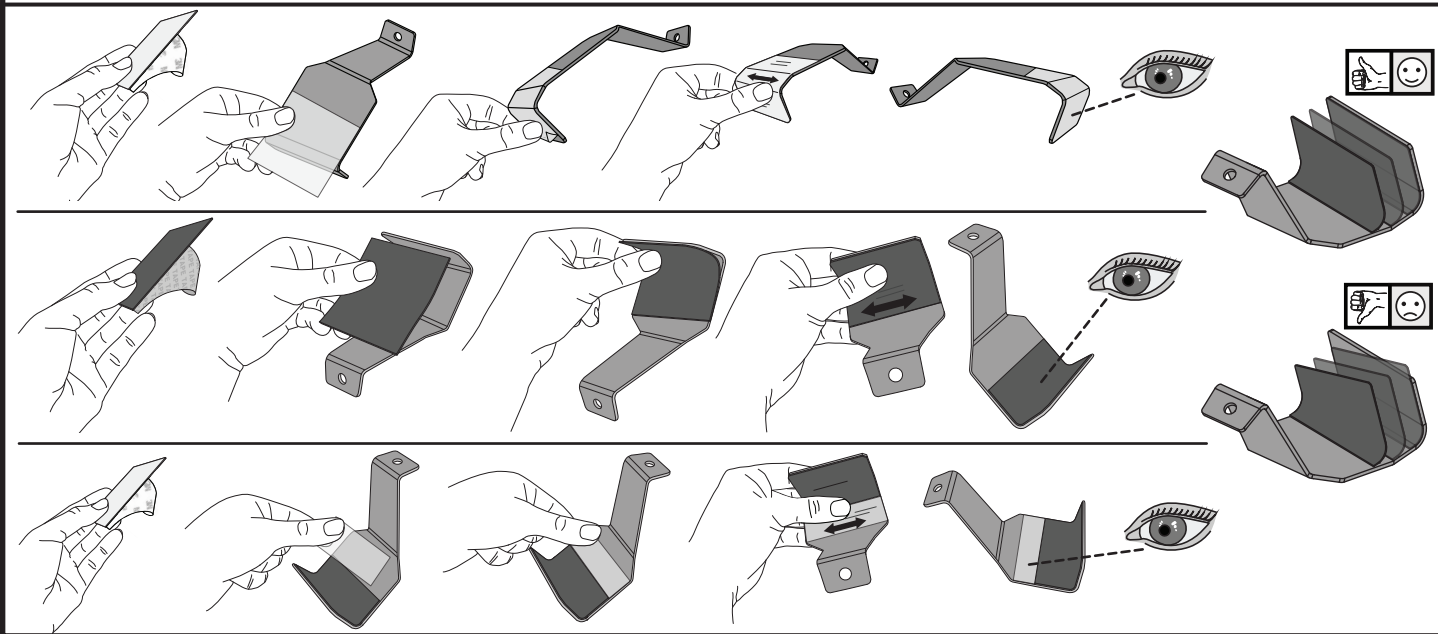
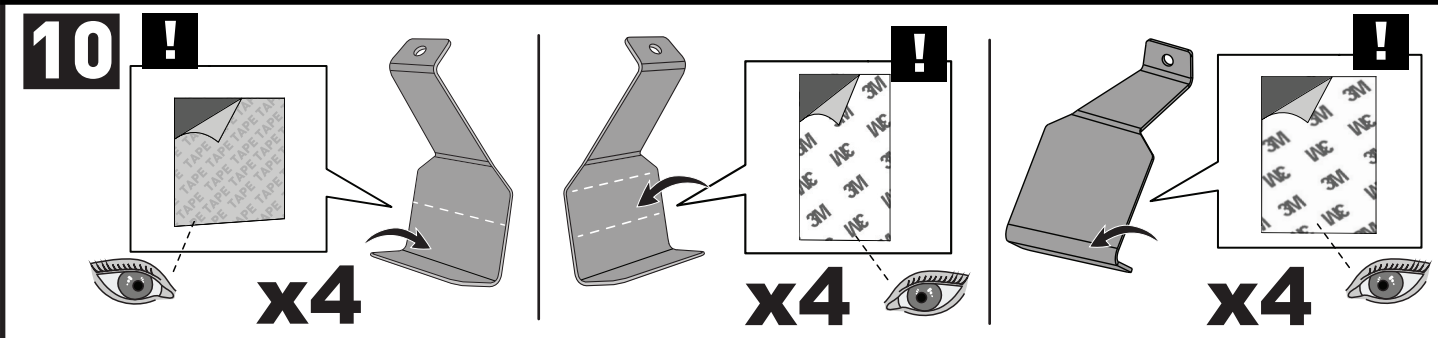

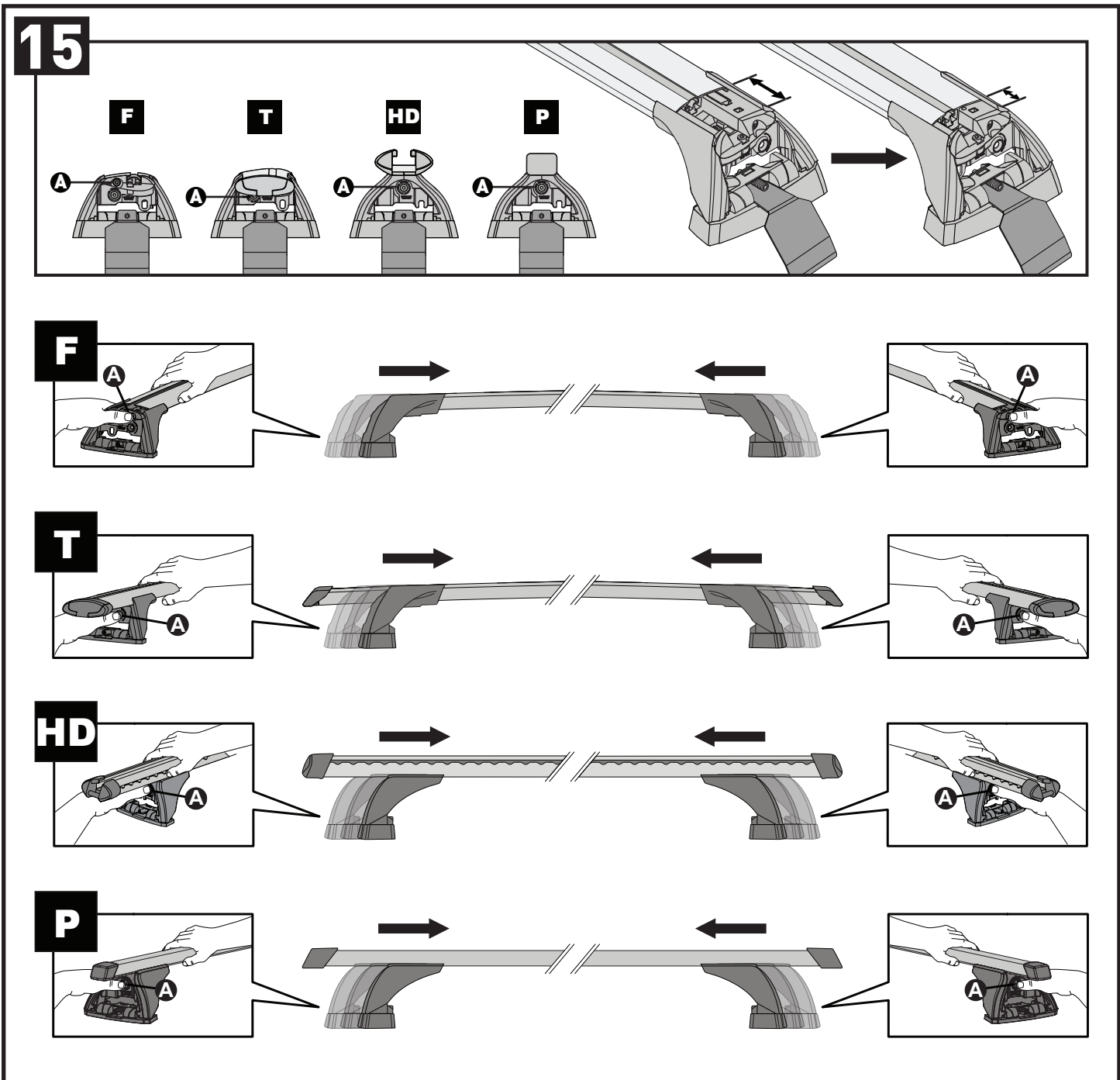
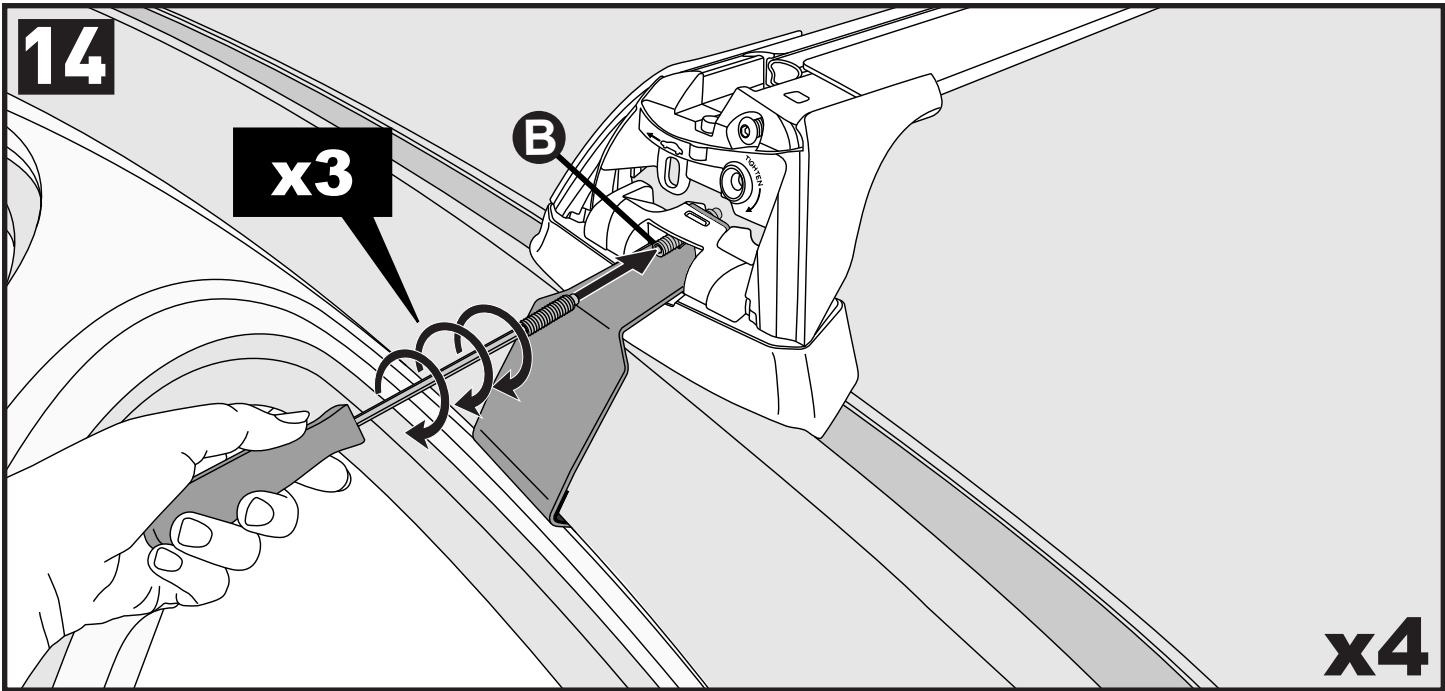

16

CLOSE • FERMER • CERRAR • GESCHLOSSEN • VICINO • FECHAR • 关紧 • ЗАКРЫТЬ

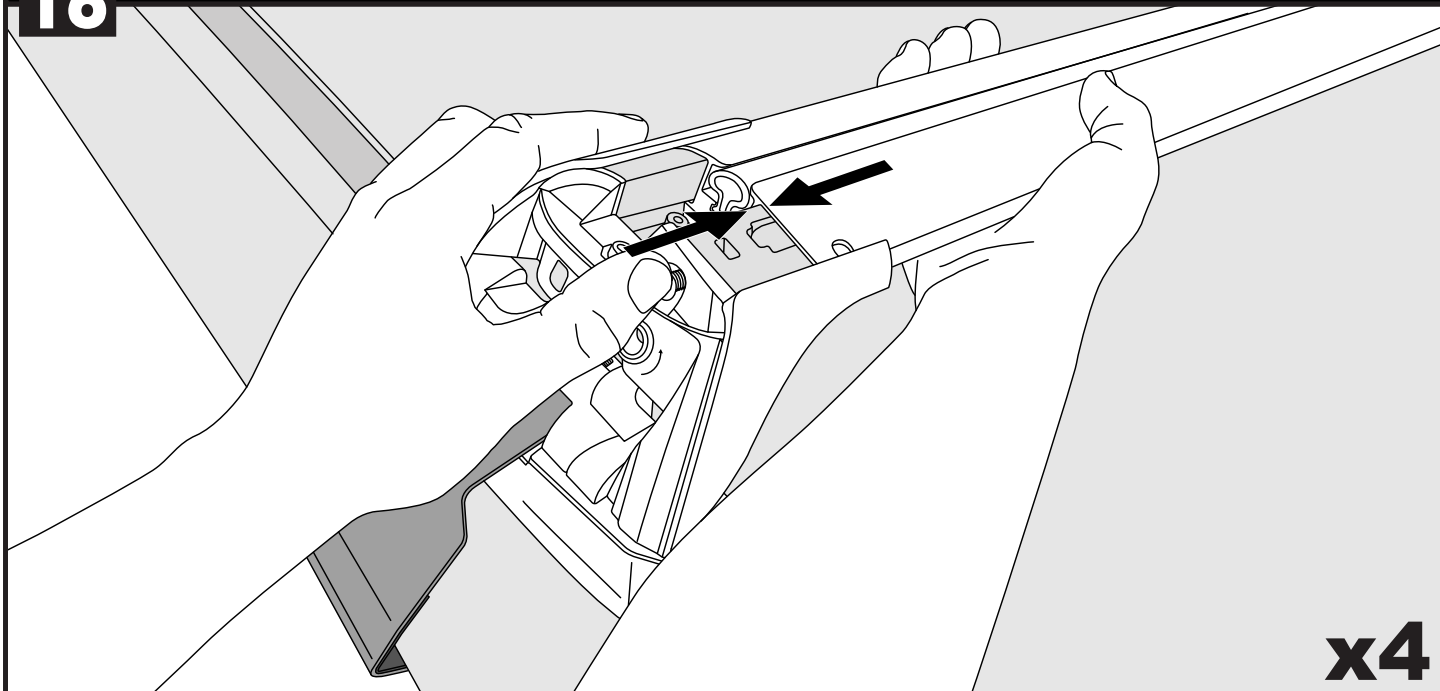

x4

17

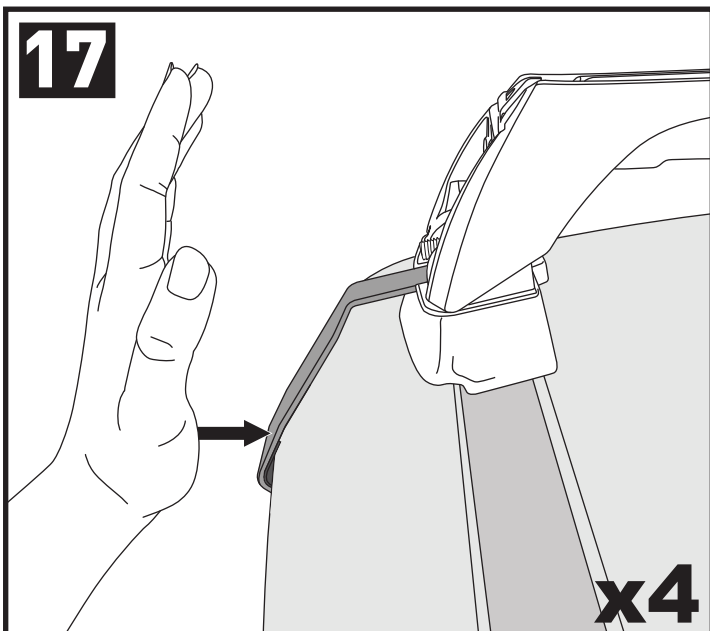

x4

18

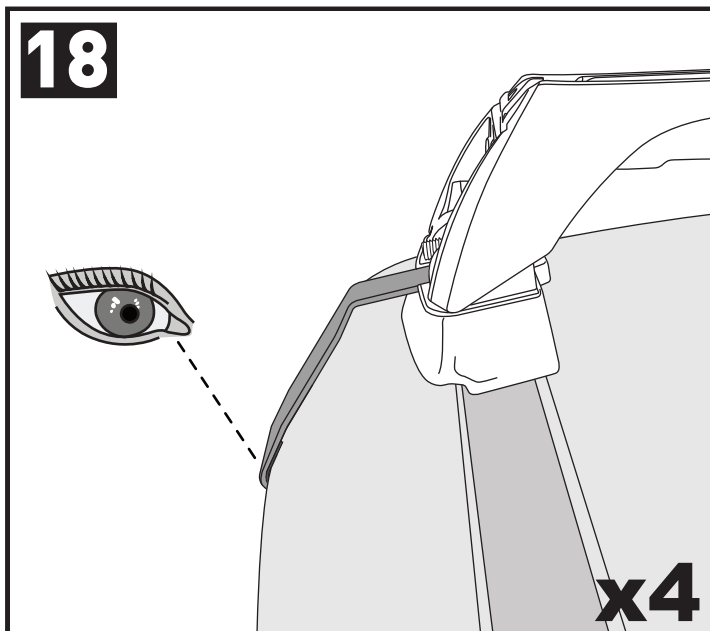

x4

ATTENTION • ATENCIÓN • AUFMERKSAMKEIT • ATTENZIONE • ATENÇÃO • 注意 • ВНИМАНИЕ

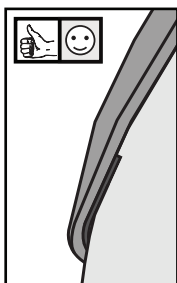

F

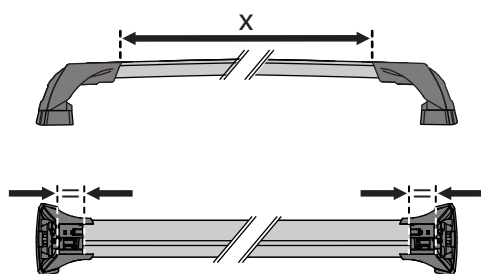

T

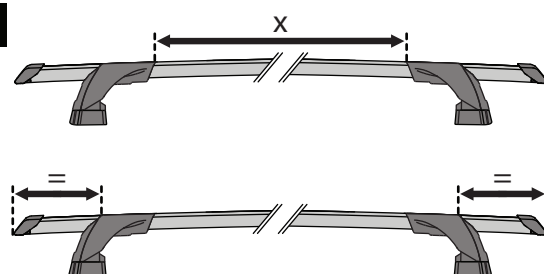

HD

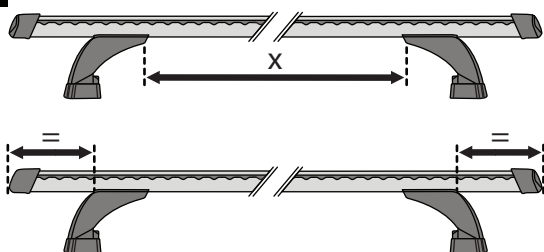

P

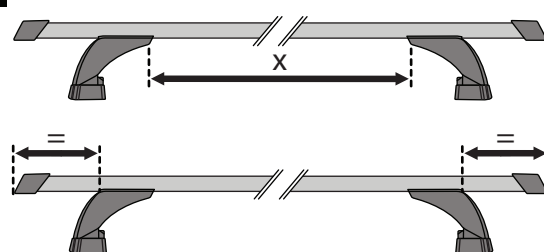

19

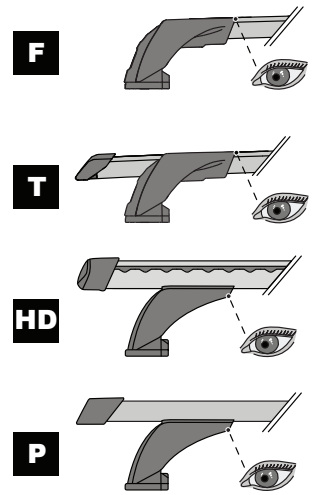
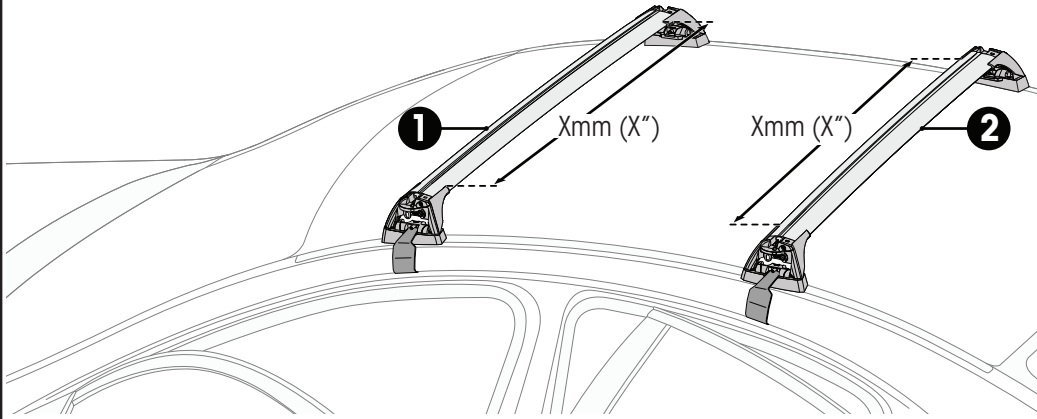

		1	2
Nissan Micra, 5dr Hatch 10 - Jan 15	CN	X = 730 mm (28 3/4")	X = 705 mm (27 3/4")
Nissan Micra K13, 5dr Hatch 10 - Jan 15	AU, NZ, ZA, EU	X = 730 mm (28 3/4")	X = 705 mm (27 3/4")
Nissan Micra K13, 5dr Hatch 15 +	AU, NZ, ZA, EU	X = 730 mm (28 3/4")	X = 705 mm (27 3/4")

20

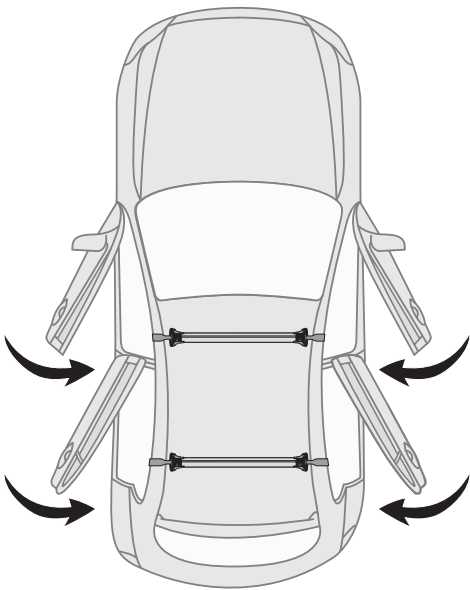

21



Make Model, Variant, xdr	Vehicle Type xx+	A	B
AU, NZ, CN, US, EU, ZA	xxxx mm (xxx mm)	xxxx mm (xxx mm)	xxxx mm (xxx mm)
AU, NZ, CN, US, EU, ZA	xxxx mm (xxx mm)	xxxx mm (xxx mm)	xxxx mm (xxx mm)
AU, NZ, CN, US, EU, ZA	xxxx mm (xxx mm)	xxxx mm (xxx mm)	xxxx mm (xxx mm)

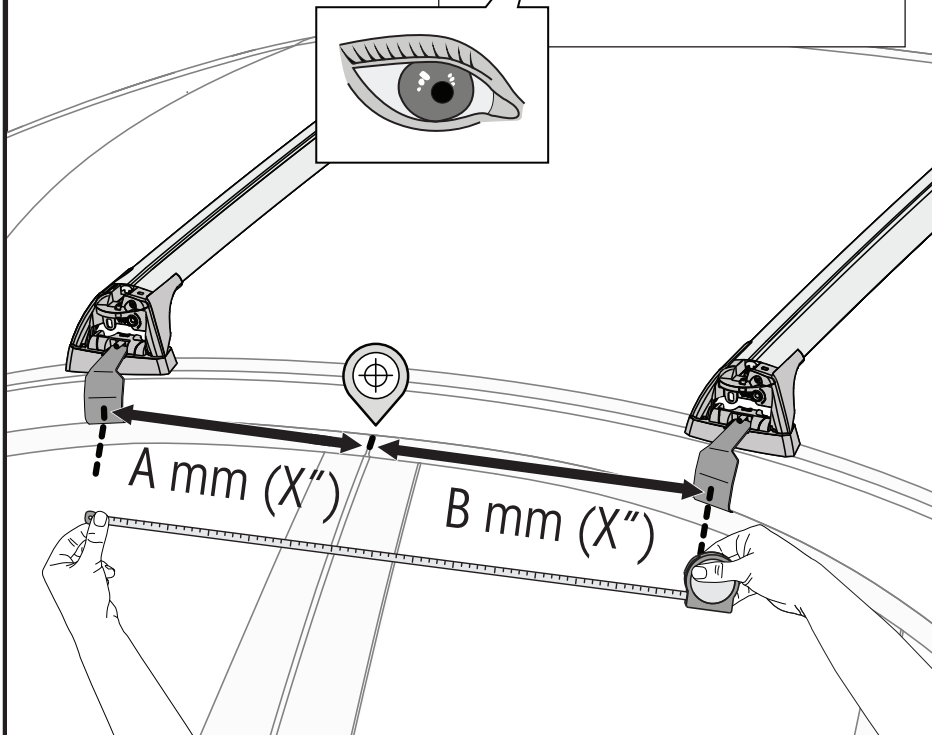

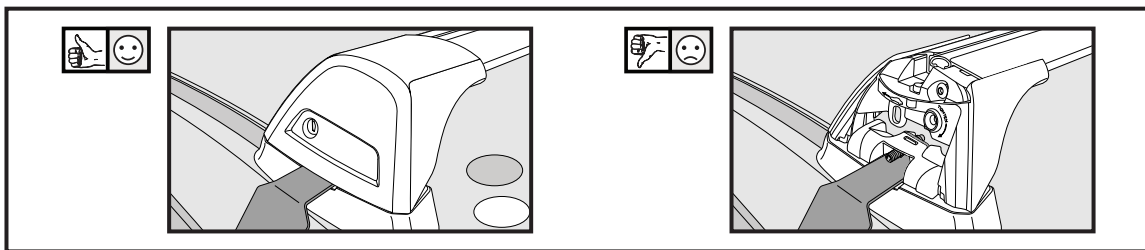
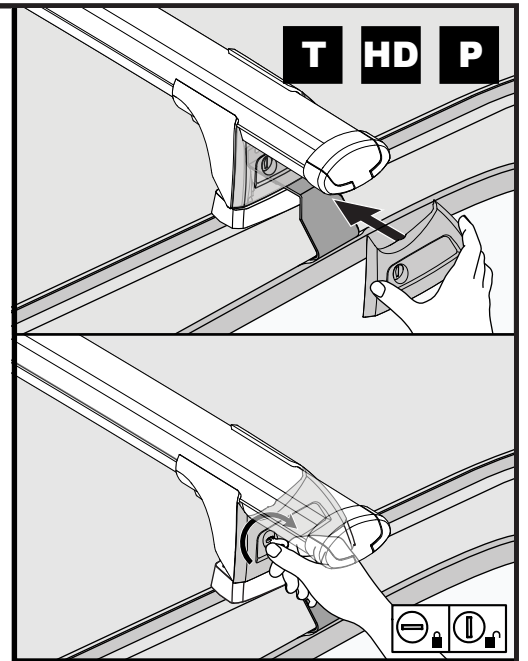
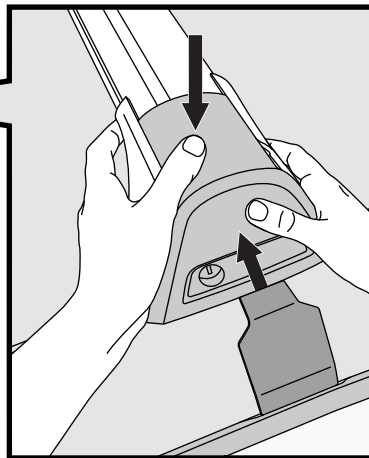
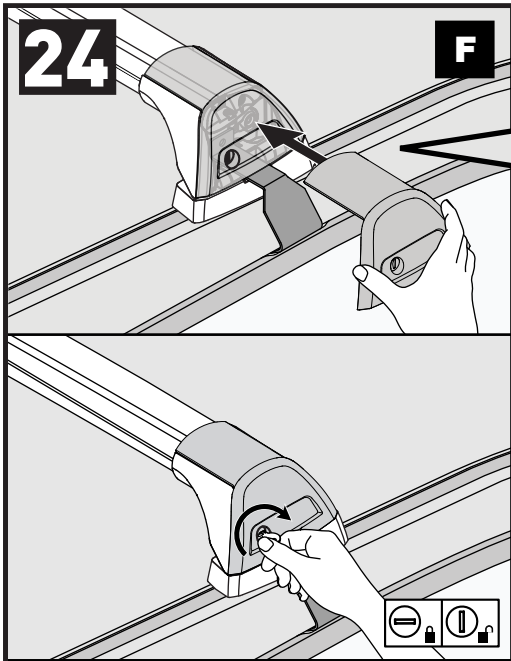
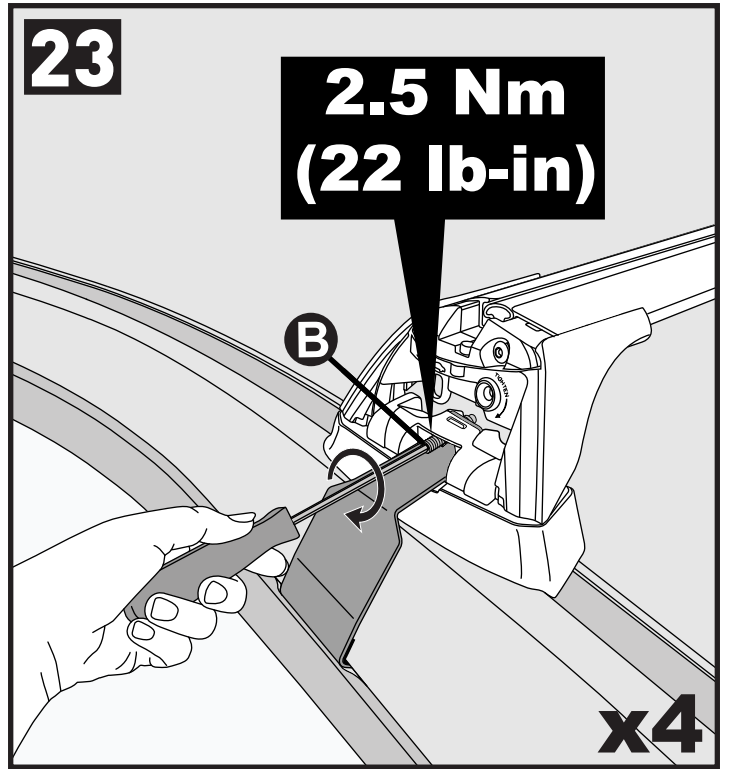
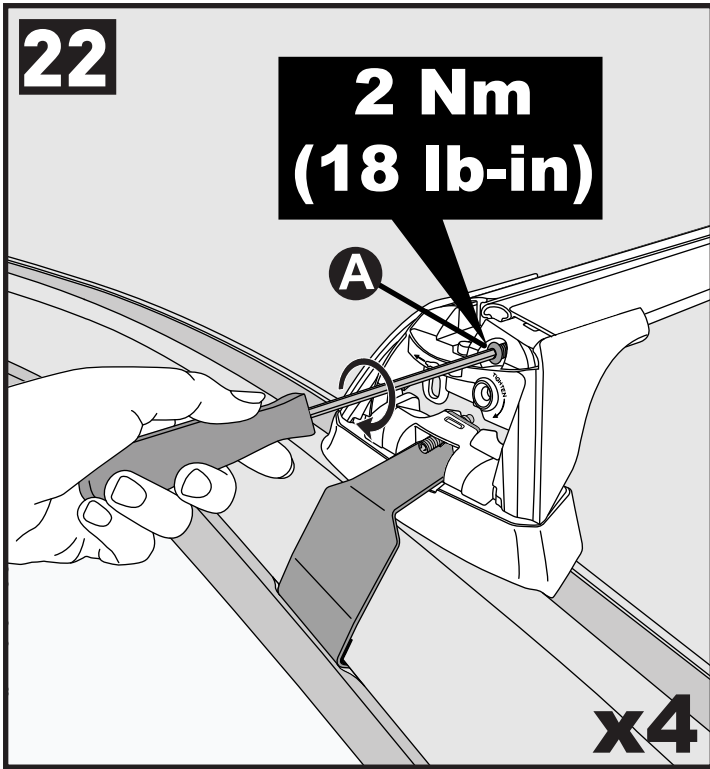

x4

ATTENTION • ATENCIÓN • AUFMERKSAMKEIT • ATTENZIONE • ATENÇÃO • 注意 • ВНИМАНИЕ

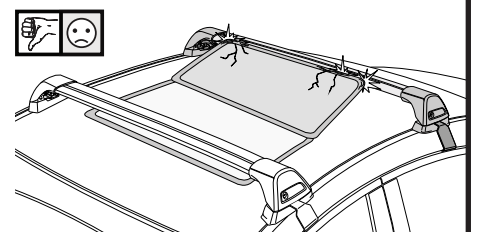
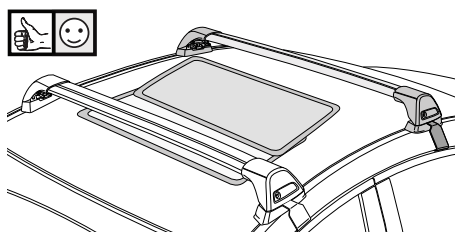
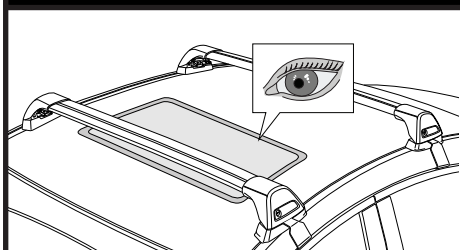

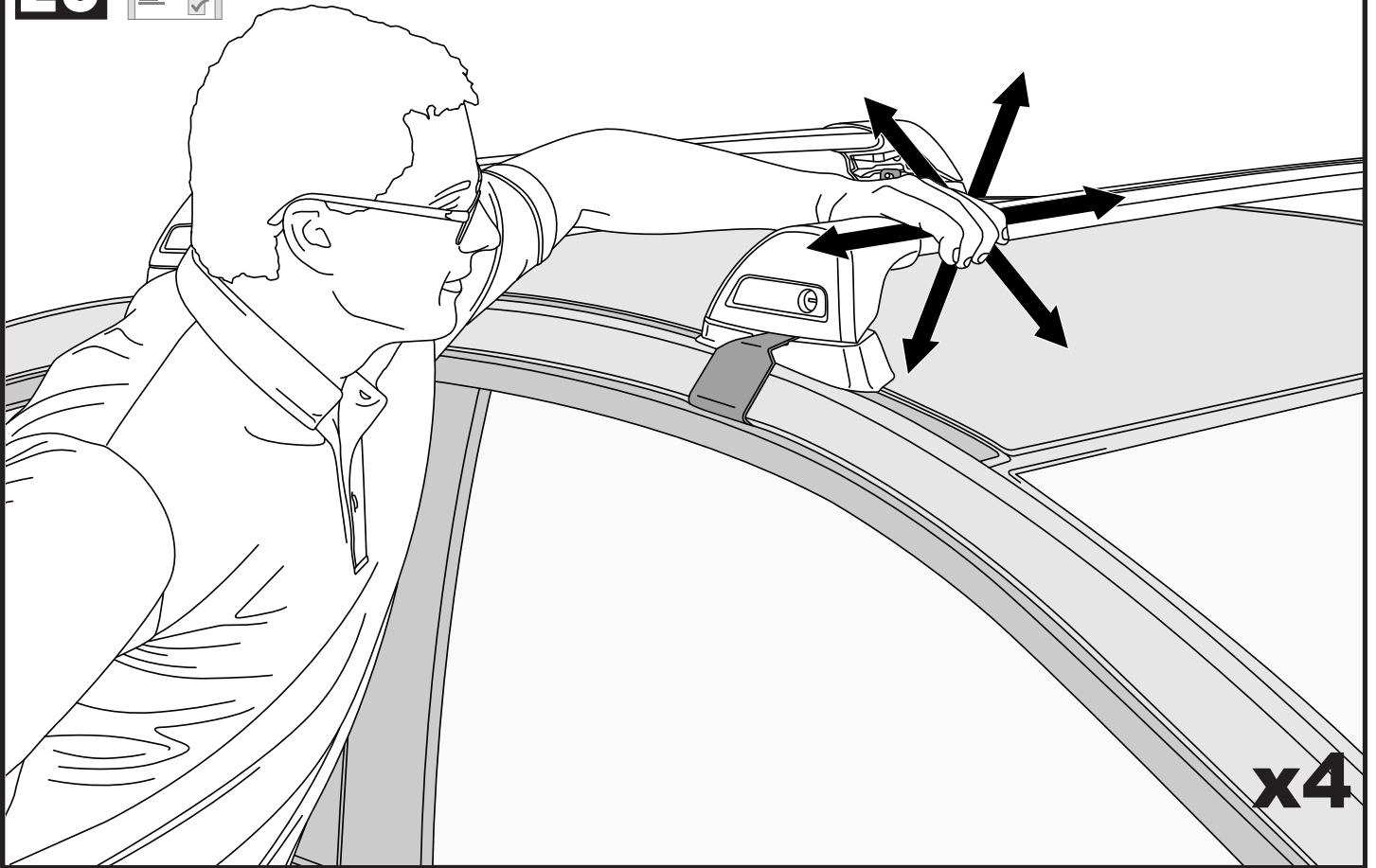
25
ATTENTION • ATENCIÓN • AUFMERKSAMKEIT • ATTENZIONE • ATENÇÃO • 注意 • ВНИМАНИЕ

- EN** Please read safety and warranty booklet included with this product prior to use. For more information visit your local dealer.
- FR** Veuillez lire attentivement le manuel de sécurité et de garantie avant utilisation. Pour plus d'informations, visitez votre concessionnaire local.
- ES** Por favor, lea folleto de seguridad y garantía que se incluye con este producto antes de su uso. Para obtener más información, visite a su distribuidor local.
- DE** Bitte lesen und beachten Sie die beiliegende Montageanleitung, Sicherheitshinweise und Garantiebedingungen bevor Sie das Produkt montieren/benutzen. Für weitere Informationen kontaktieren Sie bitte Ihren Händler.
- IT** Si prega di leggere il libretto di sicurezza e garanzia incluso nel prodotto prima dell'uso. Per maggiori informazioni visita il rivenditore locale.
- PT** Por favor leia o manual de segurança e garantia incluído, antes de utilizar o produto. Para mais informações visite o seu revendedor local.
- CN** 使用前, 请仔细阅读产品内安全和保修细则。欲了解更多信息, 请咨询当地经销商。
- RU** Пожалуйста, ознакомьтесь с инструкцией перед тем, как использовать товар. Для получения более подробной информации обратитесь к местному дилеру.

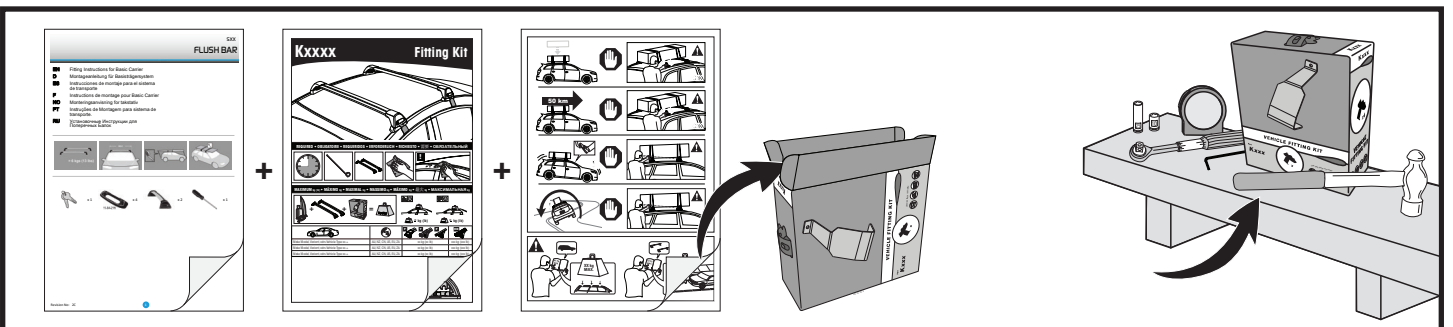
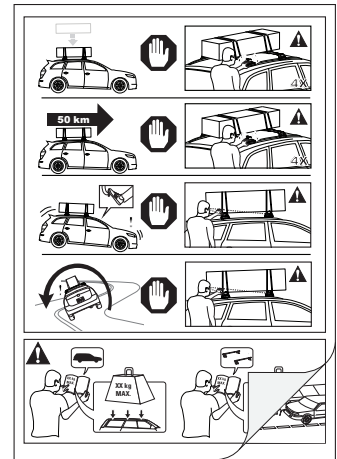

Yakima Australia Pty Ltd
17 Hinkler Court, Brendale
QLD 4500, Australia

Yakima Europe Coöperatief U.A.
Archimedesbaan 25, 3439
ME Nieuwegein, The Netherlands

Yakima Products, Inc.
15025 SW Koll Pkway,
Beaverton, OR 97006 USA