

VW TIGUAN 2016 No rails

MOCSKT 0404

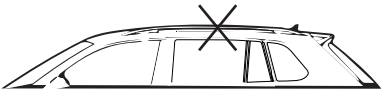

MOCSRR0AC0011 cm 124

MOCSRR0AL0007 cm 124

1 - L1169/17 Ant. Sx		2 - L1314/2 post.		2 - L1204/4	
1 - L1169/27 Ant. Dx				2 - L1058/8	
1 - L1206/5 Ant. Sx		2 - L1058/7		8 - RCVM6X9Q	
1 - L1206/6 Ant. Dx		2 - RCVM6X16TSQ		4 - RC20200026	
		2 - RCRD8Q		1 - RCBR5	
			16 mm	1 - RCBR4	

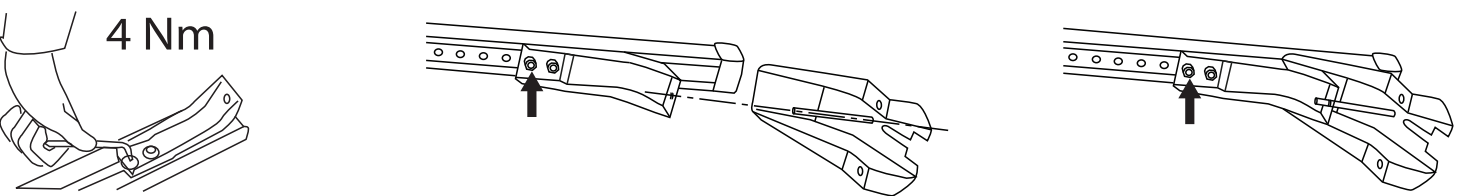
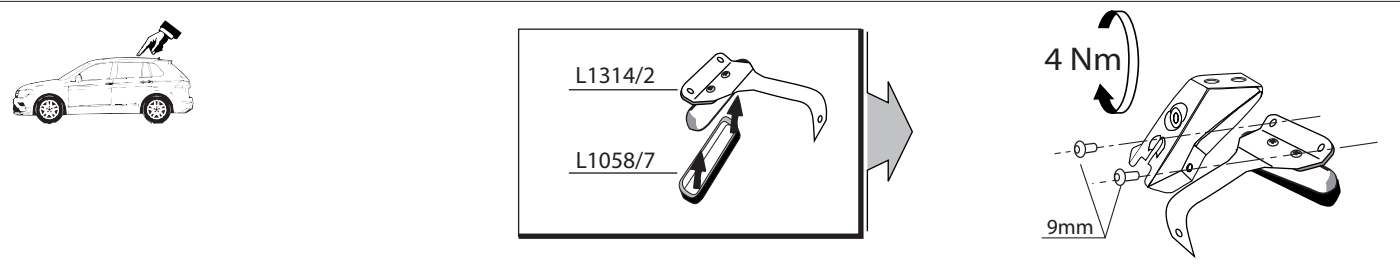
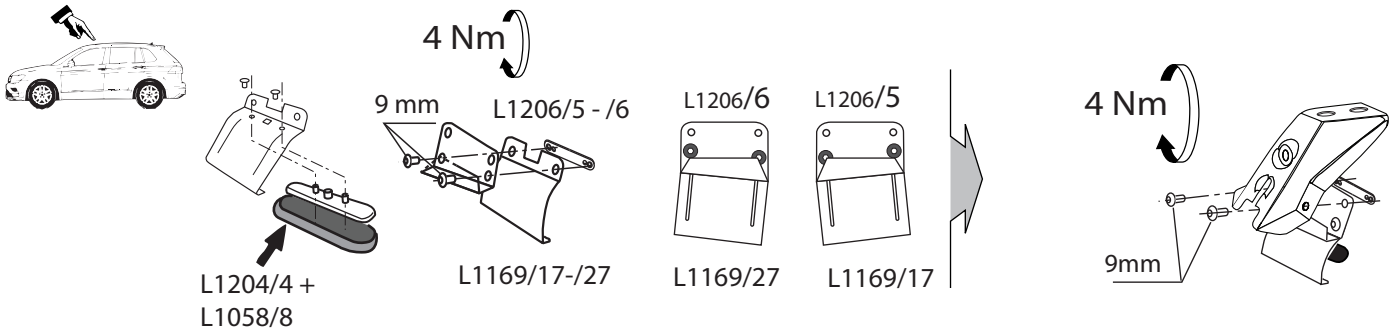

MOCSKT 0404

!!!



MOCSRROAC0011 cm 124
MOCSRROAL0007 cm 124

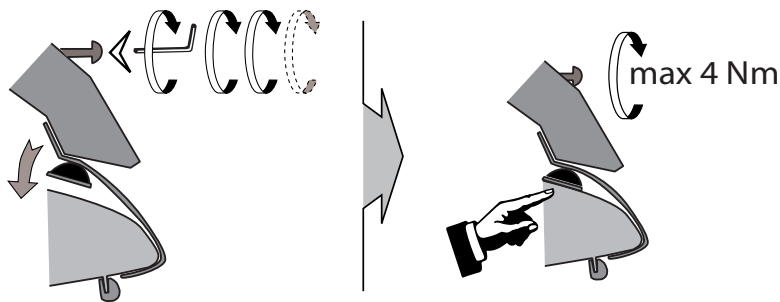
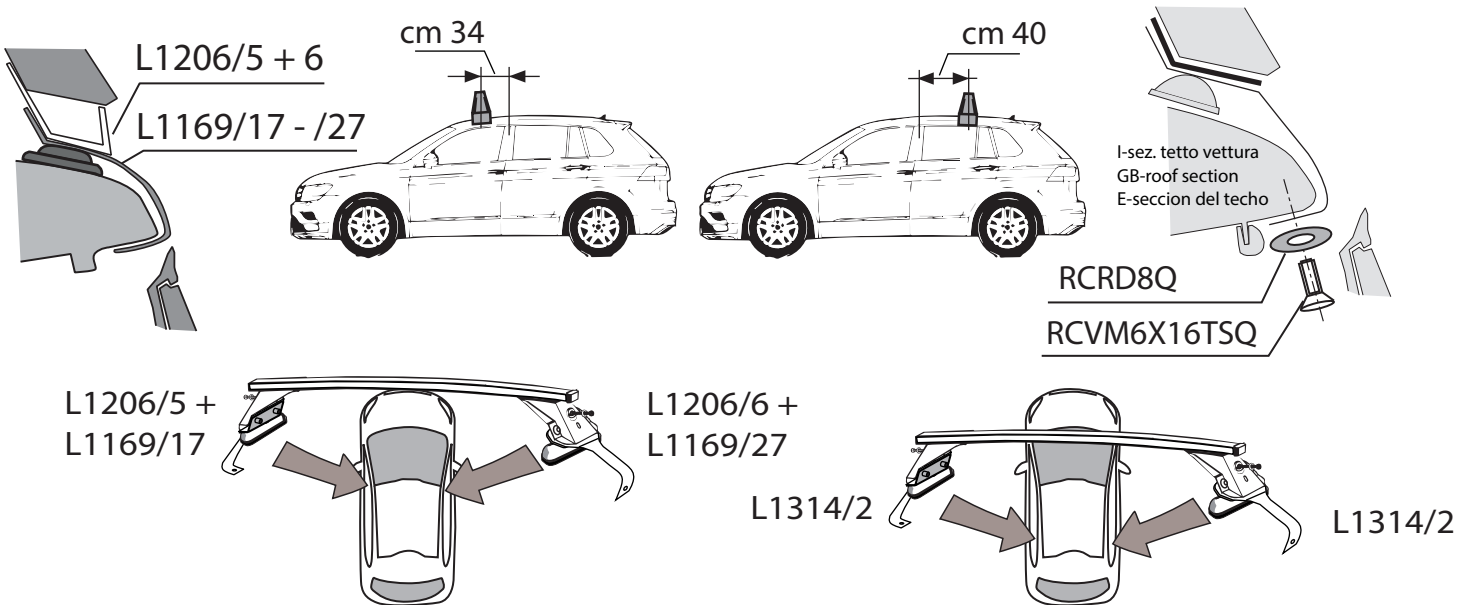
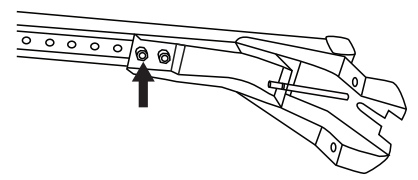
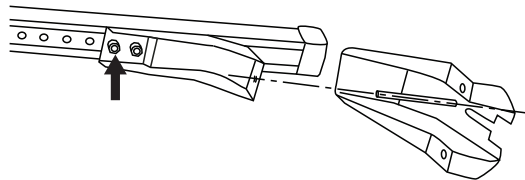
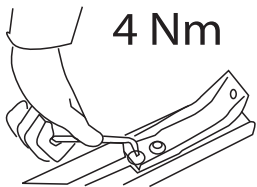
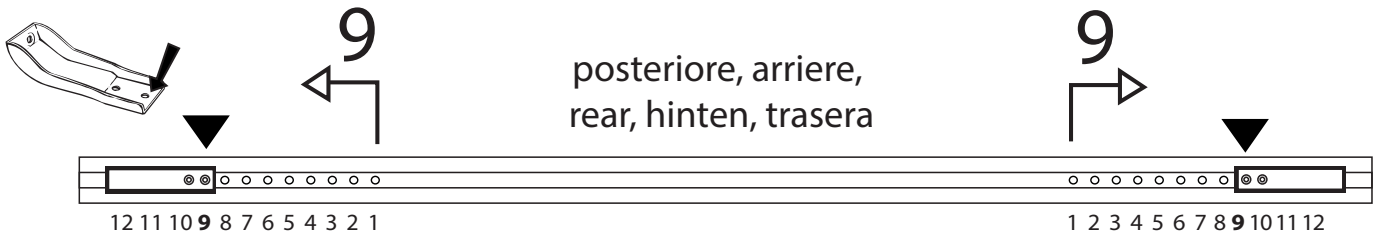

I - Per stringere, usare la chiave come indicato nel disegno. (Non si assumono responsabilità per danni causati dall'impiego di chiavi diverse da quella in dotazione al prodotto).
 F - Pour serrer, utiliser la clé comme indique ci dessous.

GB - To tighten please use the wrench as per the drawing.
 D - Zum Anziehen benutzen Sie bitte den Inbusschlüssel, nur wie auf dem Bild dargestellt.
 E - Para el correcto ajuste, utilizar la llave fija tal y como se indica en la imagen

