

# OPEL Grandland X 2017 no rails

**MOCSRROAC0011 cm 124**

**MOCSRROAL0007 cm 124**

Patent pending  
**MOCSKT 0372**

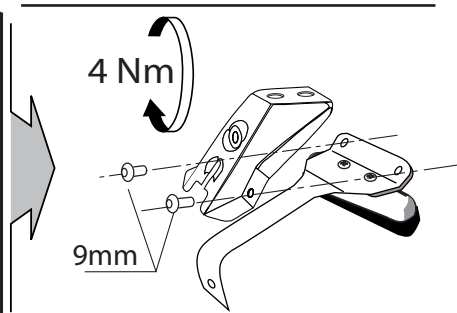
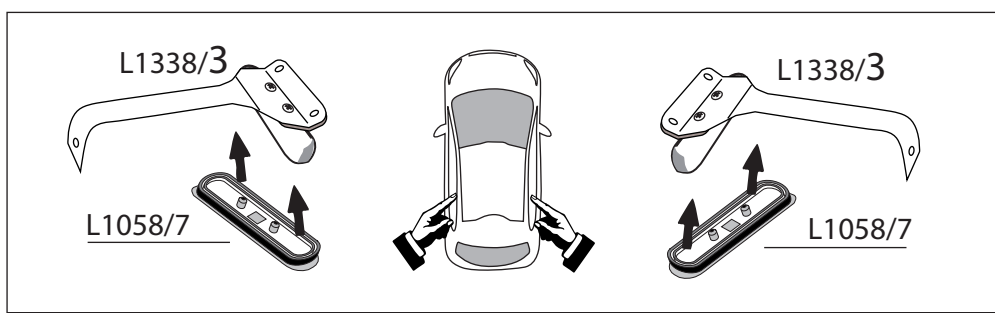
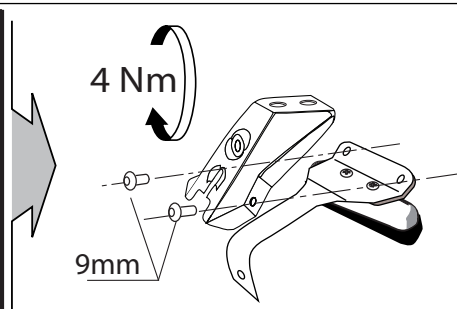
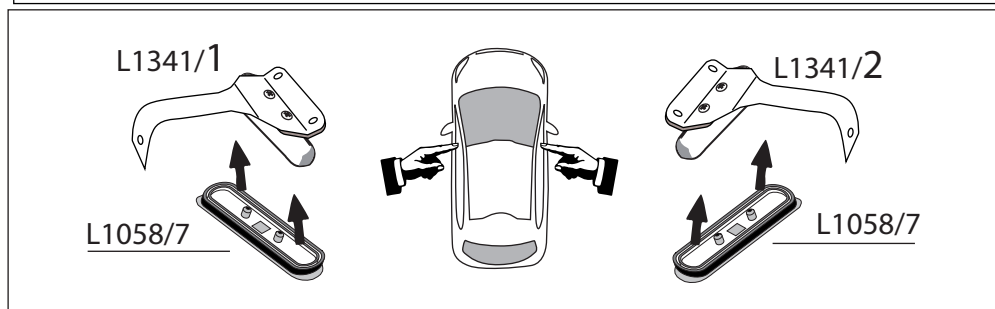
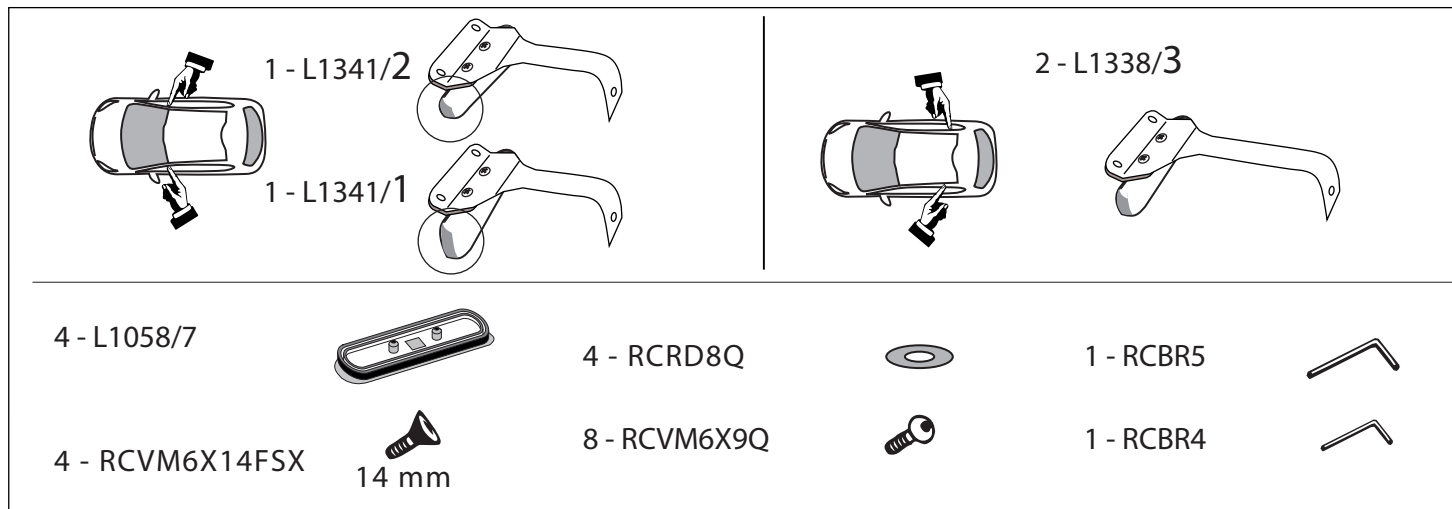

**MOCSRROAC0011 cm 124**  
**MOCSRROAL0007 cm 124**

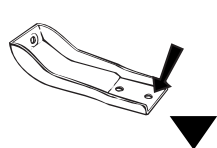

**10**

anteriore, avant, front,  
vorne, delantera

**10**

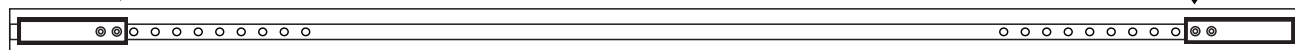

12 11 10 9 8 7 6 5 4 3 2 1

1 2 3 4 5 6 7 8 9 10 11 12

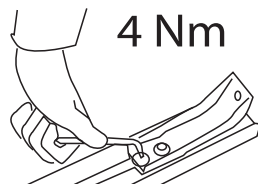

**4 Nm**

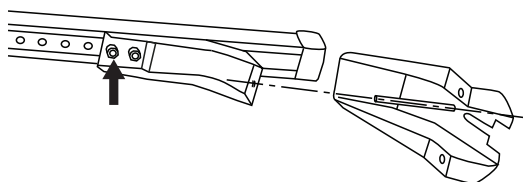

**10**

**10**

# MOCSKT 0372

!!!



**MOCSRR0AC0011 cm 124**  
**MOCSRR0AL0007 cm 124**

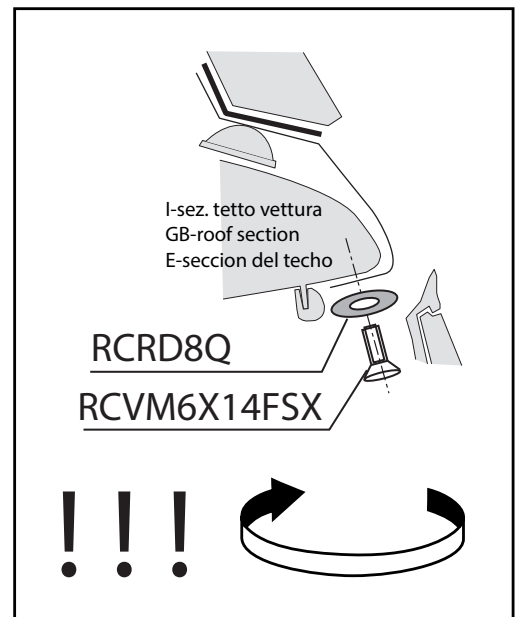
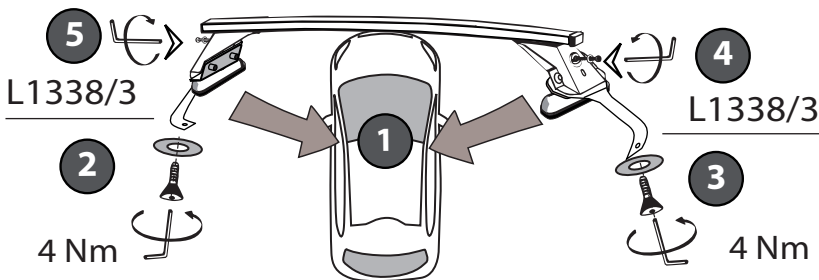
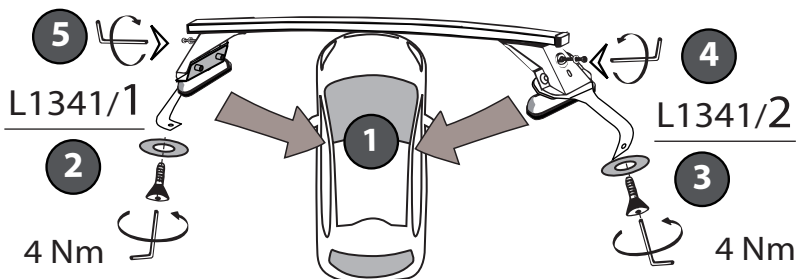
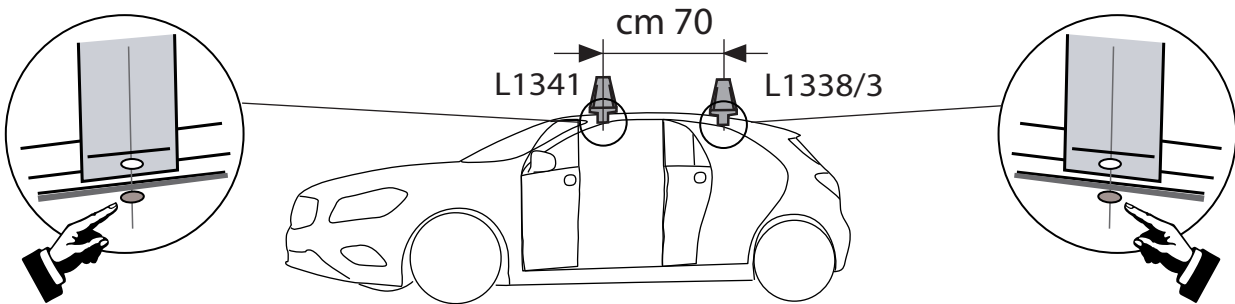
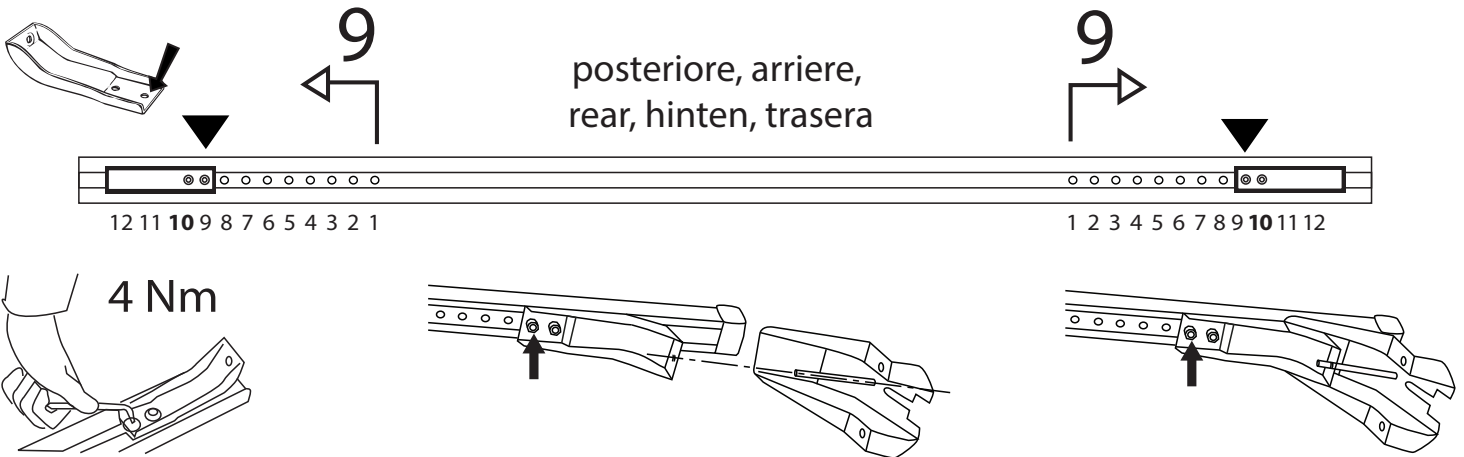

I - Per stringere, usare la chiave come indicato nel disegno. (Non si assumono responsabilità per danni causati dall'impiego di chiavi diverse da quella in dotazione al prodotto).

F - Pour serrer, utiliser la clé comme indique ci dessous.

GB - To tighten please use the wrench as per the drawing.

D - Zum Anziehen benutzen Sie bitte den Inbusschlüssel, nur wie auf dem Bild dargestellt.

E - Para el correcto ajuste, utilizar la llave fija tal y como se indica en la imagen

