

# SEAT Ateca no rails model 2016 ŠKODA Karoq no rails model 2017

## MOC SKT 0357

### MOC SRR0AC011 cm 124

### MOC SRR0AL007 cm 124



1 - L1342/3 ant. sx 1 - L1342/4 ant. dx		2 - L954 post. 4 - L1204/4 4 - L1058/8		8 - RCVM6X9Q 4 - RC20200026 1 - RCBR5	
--	--	--	--	---	--

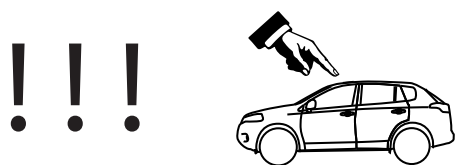
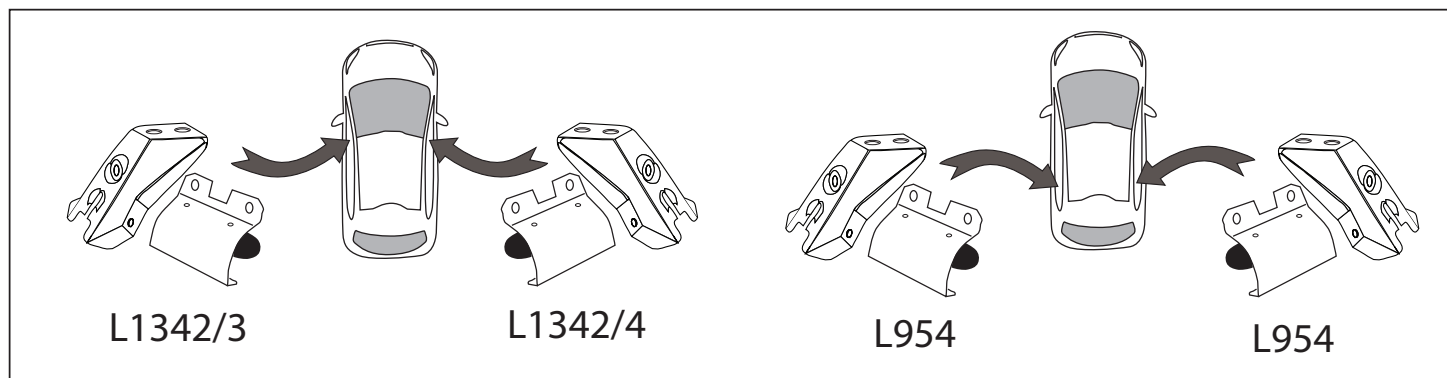
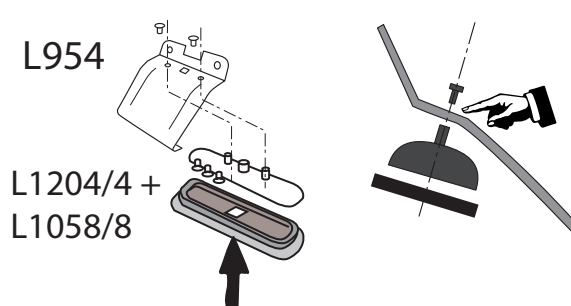
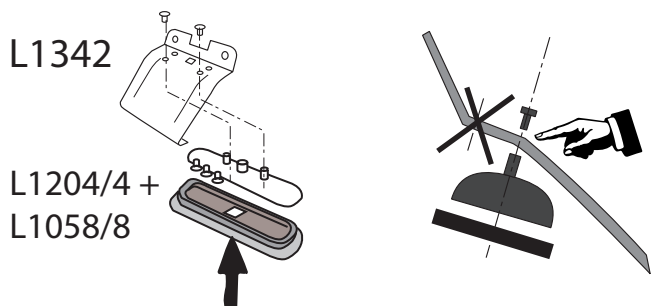

**MOC SRR0AC011 cm 124**  
**MOC SRR0AL007 cm 124**

anteriore, avant, front,  
vorne, delantera

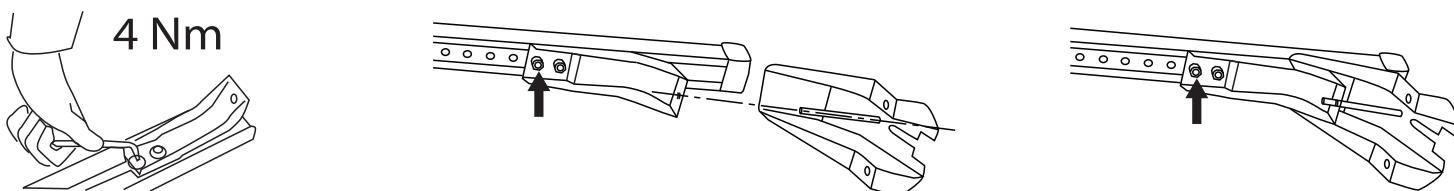
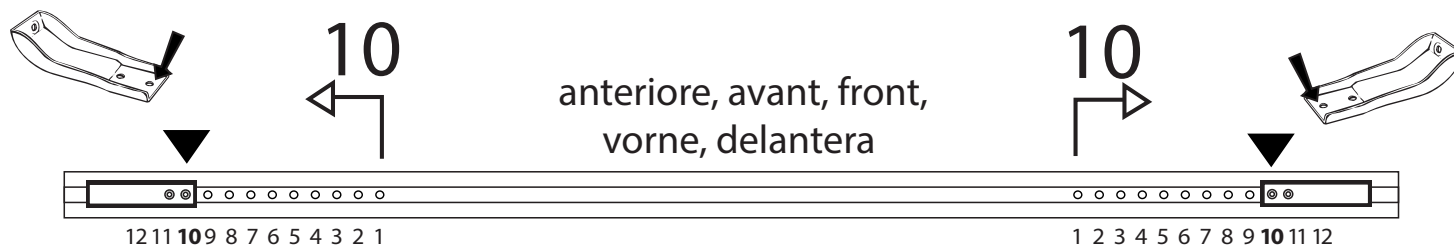

# MOCSKT 0357

!!!



**MOCSRR0AC011 cm 124**  
**MOCSRR0AL007 cm 124**

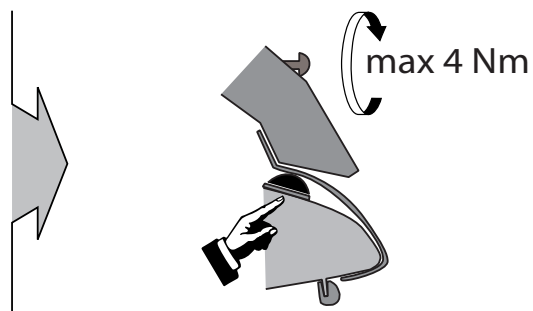
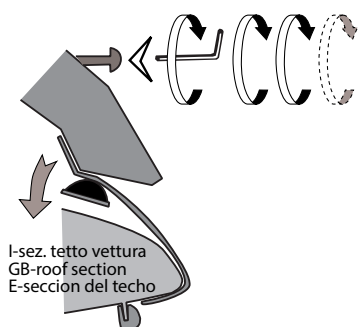
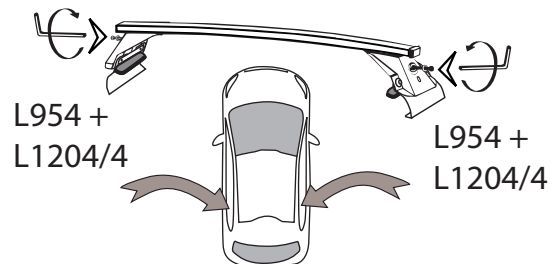
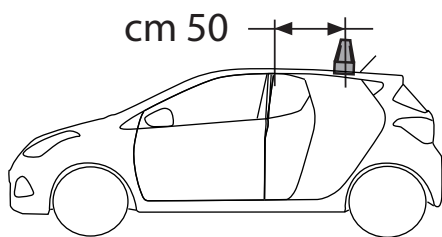
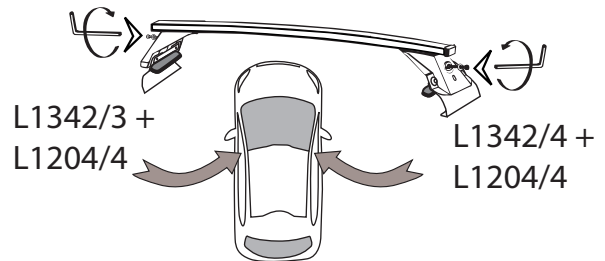
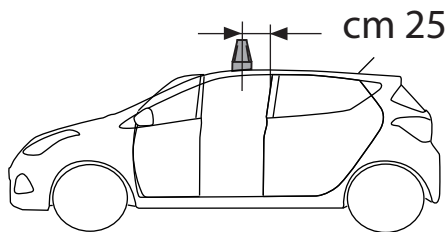
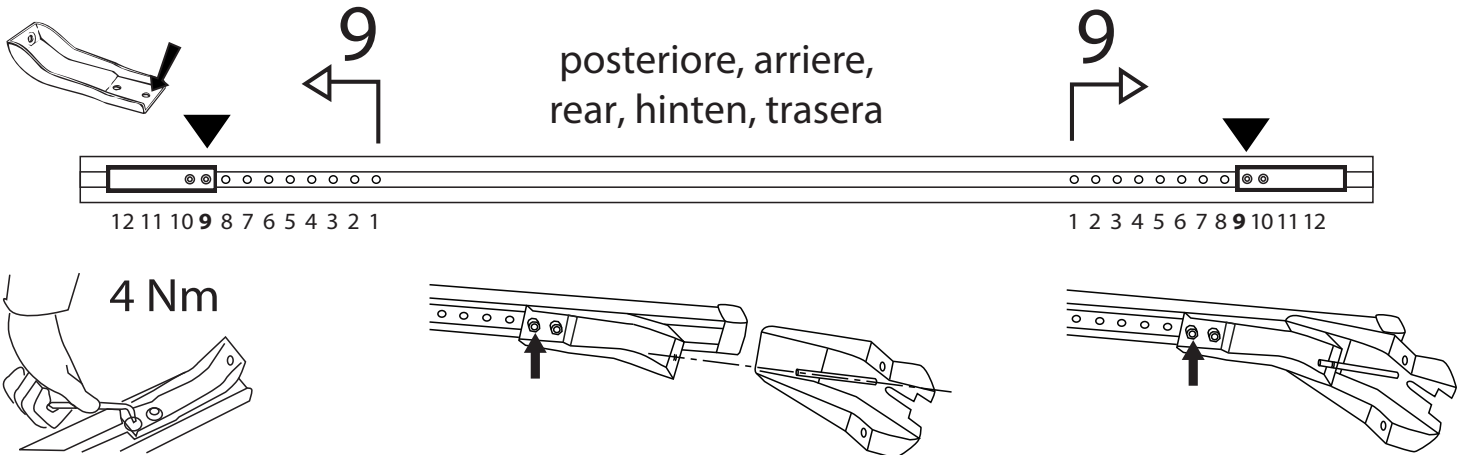

I - Per stringere, usare la chiave come indicato nel disegno. (Non si assumono responsabilità per danni causati dall'impiego di chiavi diverse da quella in dotazione al prodotto).  
 F - Pour serrer, utiliser la clé comme indique ci dessous.

GB - To tighten please use the wrench as per the drawing.  
 D - Zum Anziehen benutzen Sie bitte den Inbusschlüssel, nur wie auf dem Bild dargestellt.  
 E - Para el correcto ajuste, utilizar la llave fija tal y como se indica en la imagen

