

AUDI Q2 no rails model 2016

Patent pending
MOCSKT 349

MOCSRR0AC010 cm 110
MOCSRR0AL006 cm 110



<p>1 - L1327/2</p> <p>1 - L1327/1</p>		<p>4 - L1058/7</p>	<p>8 - RCVM6X9Q</p>
<p>1 - L1328/3</p> <p>1 - L1328/4</p>		<p>4 - RCVM6X14TSQ</p> <p>14 mm</p> <p>4 - RCRD8Q</p>	<p>1 - RCBR5</p> <p>1 - RCBR4</p>

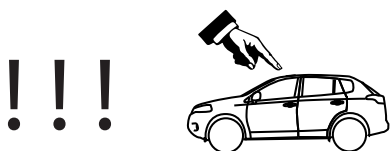
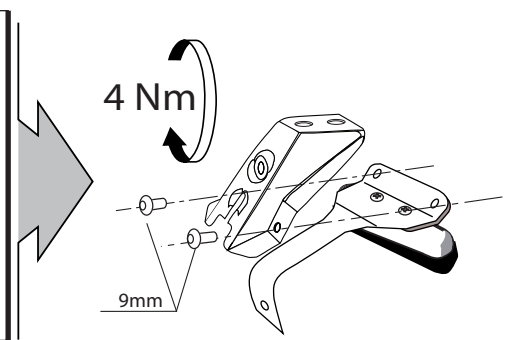
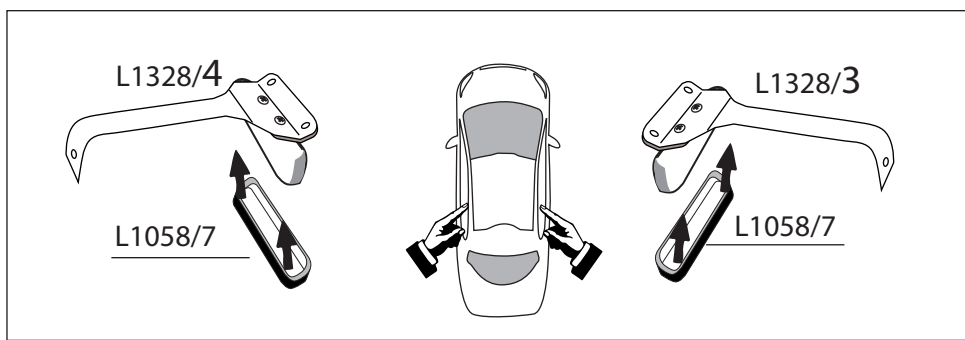
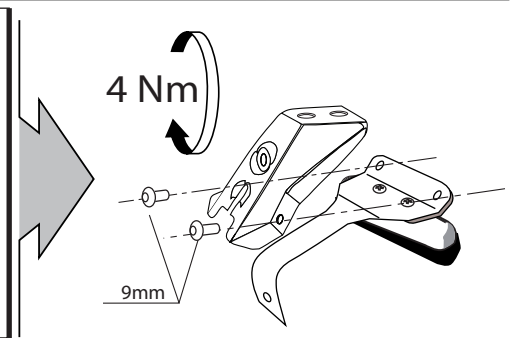
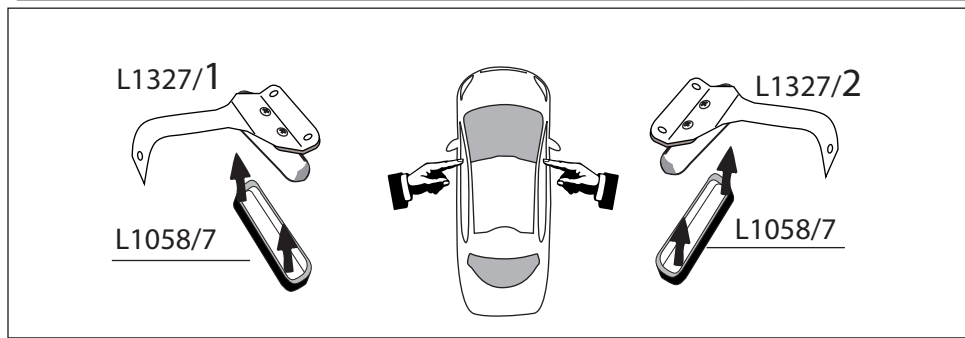

MOCSRR0AC010 cm 110
MOCSRR0AL006 cm 110

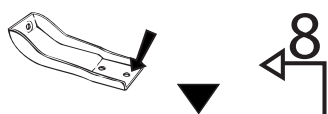

anteriore, avant, front,
vorne, delantera

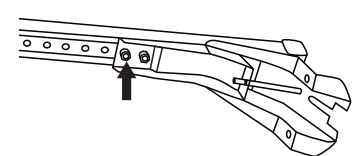
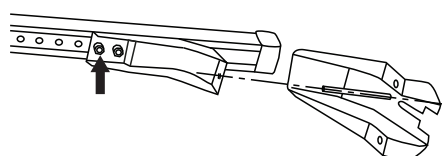
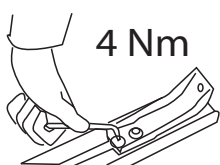
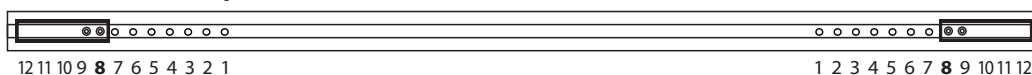
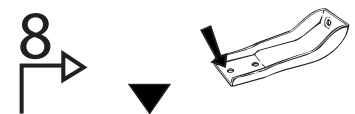

!!!



MOCSRR0AC010 cm 110
MOCSRR0AL006 cm 110

MOCSKT 349

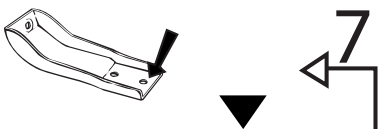

posteriore, arriere, rear,
hinten; trasera

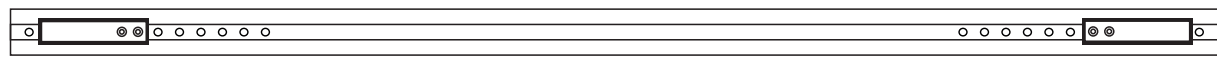
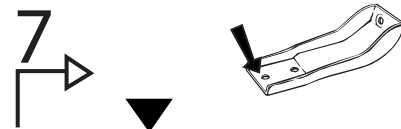

12111098 7 6 5 4 3 2 1

1 2 3 4 5 6 7 8 9 10 11 12

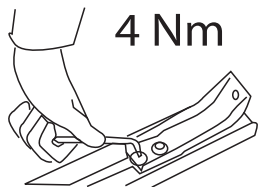

4 Nm

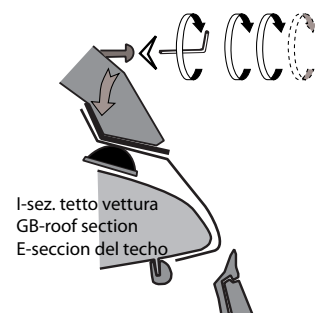
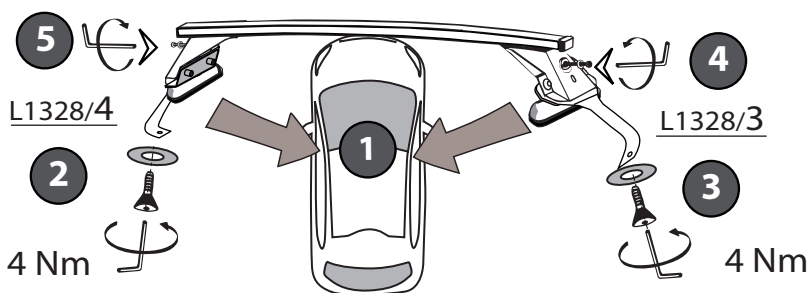
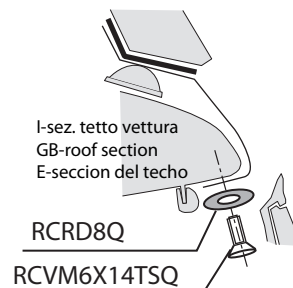
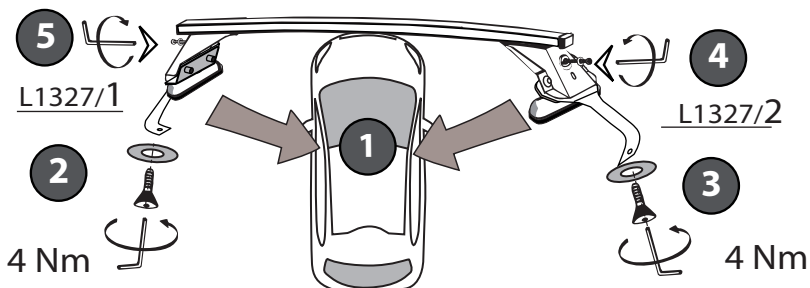
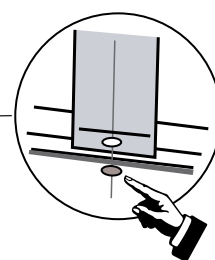
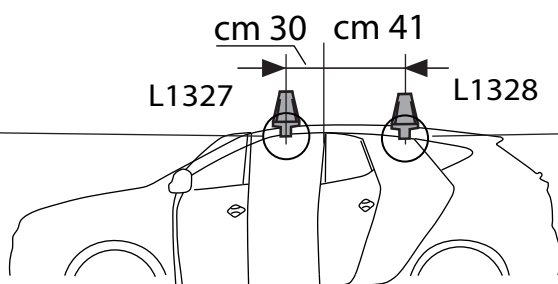
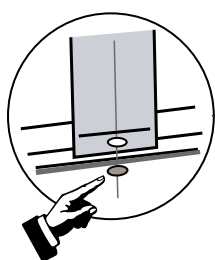
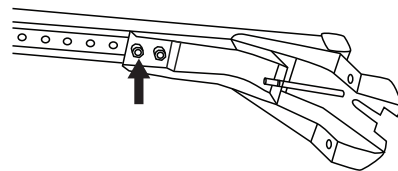
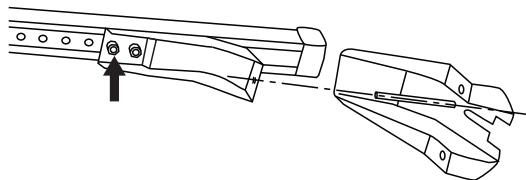

I - Per stringere, usare la chiave come indicato nel disegno. (Non si assumono responsabilità per danni causati dall'impiego di chiavi diverse da quella in dotazione al prodotto).
 F - Pour serrer, utiliser la clé comme indique ci dessus.

GB - To tighten please use the wrench as per the drawing.
 D - Zum Anziehen benutzen Sie bitte den Inbusschlüssel, nur wie auf dem Bild dargestellt.
 E - Para el correcto ajuste, utilizar la llave fija tal y como se indica en la imagen

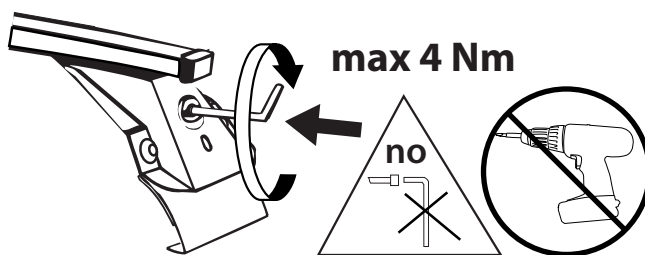

MODULA
case system

email: modulacs@modulacs.com
 web site: www.modulacs.com

Modula s.r.l.
 Loc. Penisola, 20/A
 61026 Piandimeleto (PU) ITALY
 phone +39 0722/700070
 fax +39 0722/720017

15-05-2017