

# CITROËN C3 2016 5 porte



Patent pending  
**MOCSKT 343**

**MOCSRR0AC010 cm 110**

**MOCSRR0AL006 cm 110**



<p>1 - L1358/2</p> <p>1 - L1358/1</p>	<p>4 - L1058/7</p> <p>4 - RCVM6X16TSQ</p> <p>16 mm</p>	<p>8 - RCVM6X9Q</p> <p>1 - RCBR5</p>
<p>1 - L1328/3</p> <p>1 - L1328/4</p>	<p>4 - RCRD8Q</p>	<p>1 - RCBR4</p>

L1358/1

L1058/7

L1358/2

L1058/7

4 Nm

9mm

L1328/4

L1058/7

L1328/3

L1058/7

4 Nm

9mm

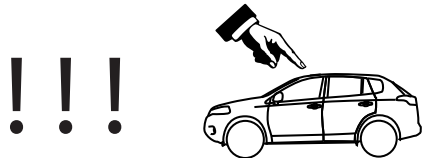

**MOCSRR0AC010 cm 110**  
**MOCSRR0AL006 cm 110**

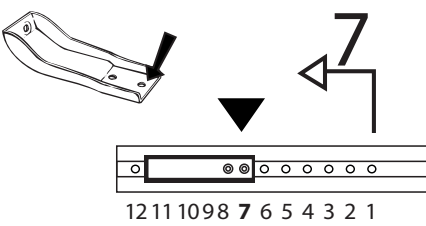

anteriore, avant, front,  
vorne, delantera

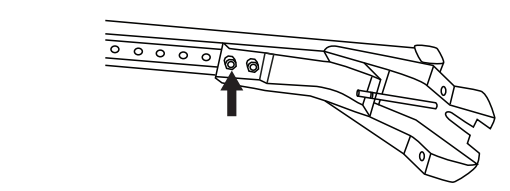
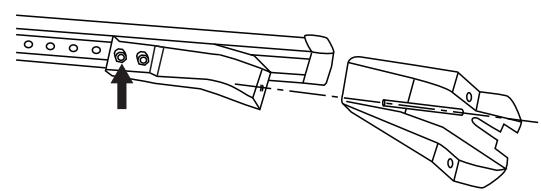
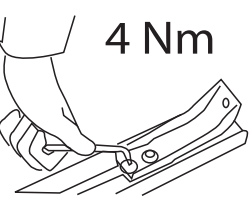
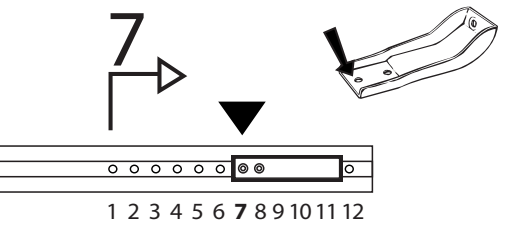

!!!



**MOCSRR0AC010 cm 110**  
**MOCSRR0AL006 cm 110**

posteriore, arriere,  
 rear, hinten, trasera

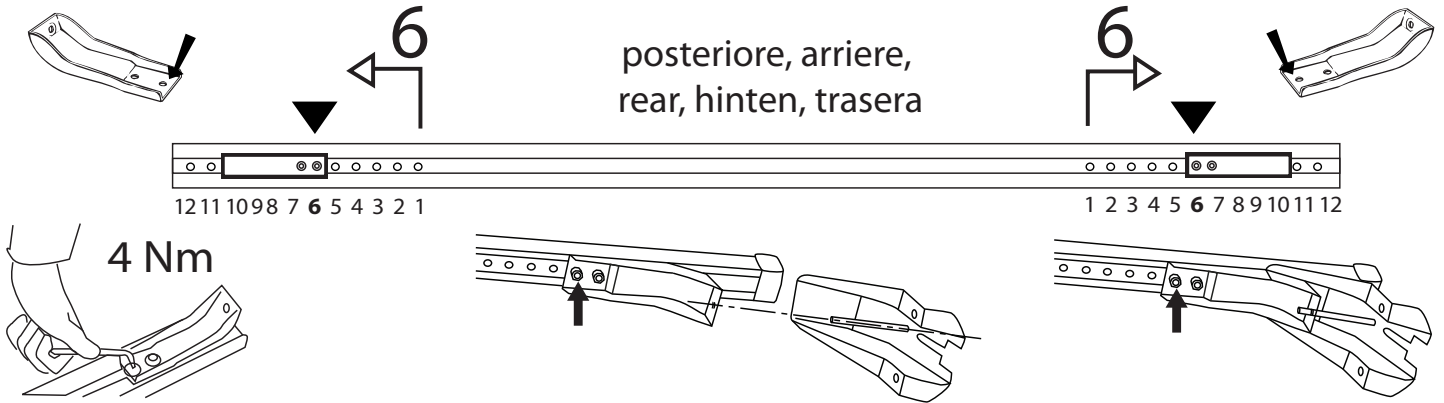

12 11 10 9 8 7 6 5 4 3 2 1

1 2 3 4 5 6 7 8 9 10 11 12

4 Nm

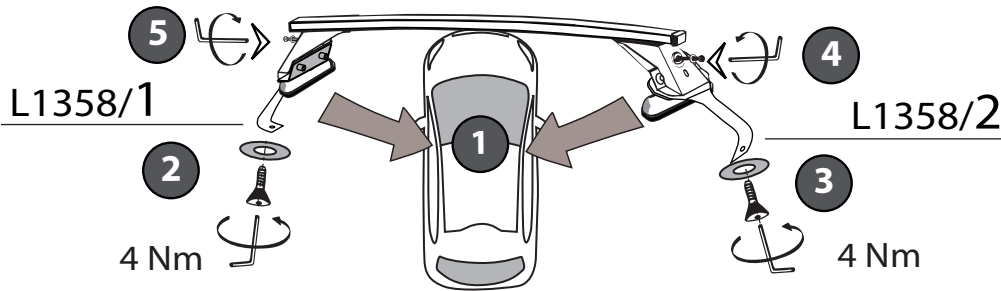
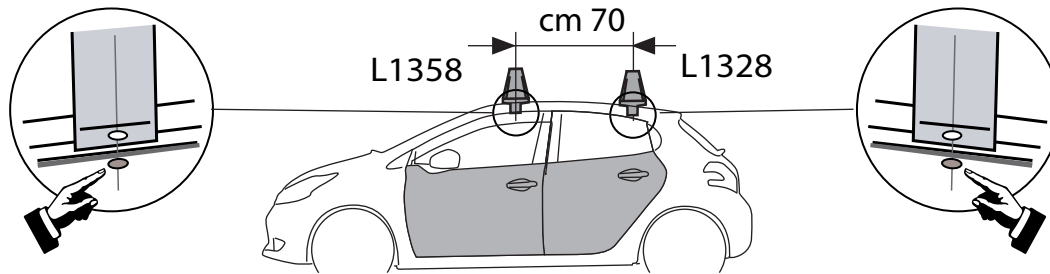

L1358/1

L1358/2

4 Nm

4 Nm

I-sez. tetto vettura  
 GB-roof section  
 E-seccion del techo

RCRD8Q  
 RCVM6X16TSQ

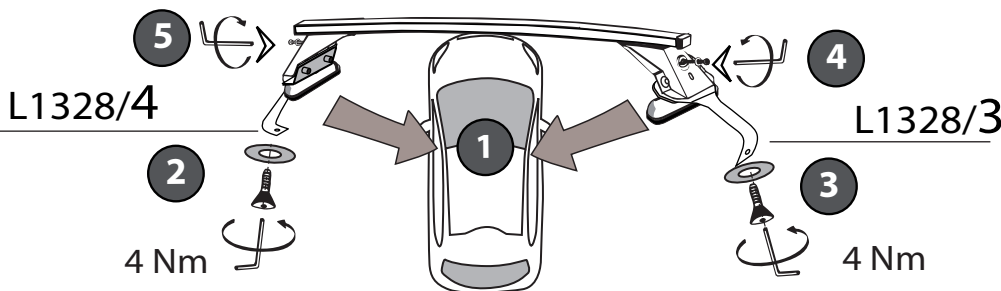

L1328/4

L1328/3

4 Nm

4 Nm

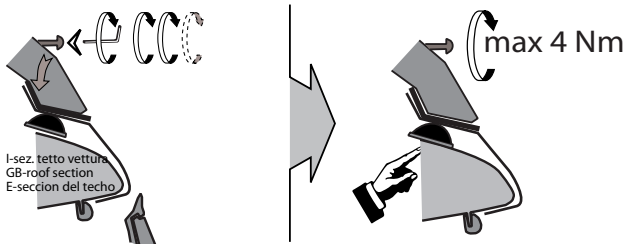

I-sez. tetto vettura  
 GB-roof section  
 E-seccion del techo

max 4 Nm

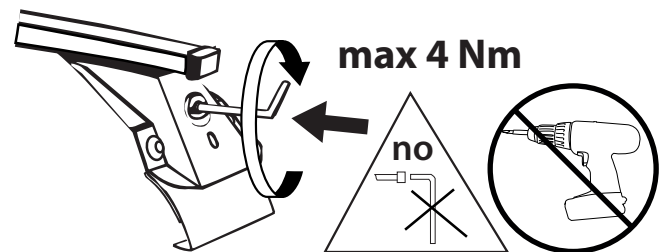

max 4 Nm

no