

MAZDA 2 2014

MOCSKT 306

MOCSRR0AC010 cm 110

MOCSRR0AL006 cm 110



1 - L1169/16 ant. sx		1 - L1342/3 post. dx		4 - RC20011935 	4 - RCVM6X13Q
1 - L1169/26 ant. dx		1 - L1342/4 post. sx		4 - L1204/4 	4 - RCVM6X9Q
				4 - L1058/5 	4 - RC20200026
				1 - RCBR5 	

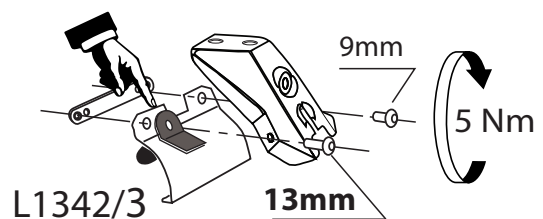
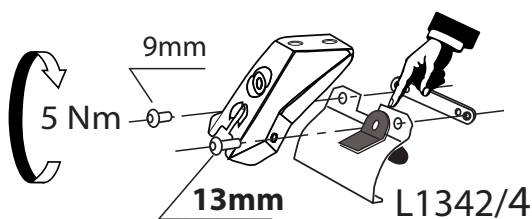
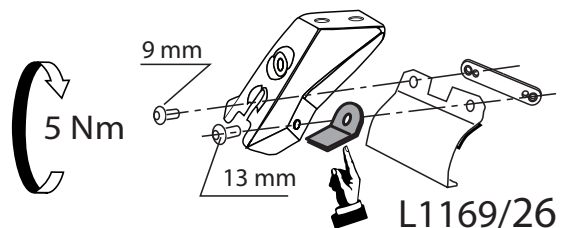
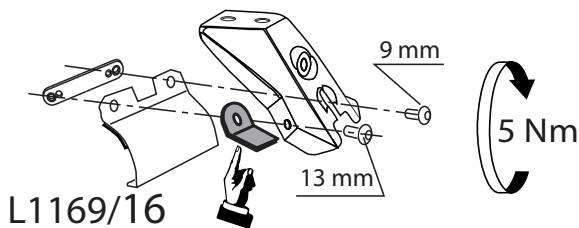
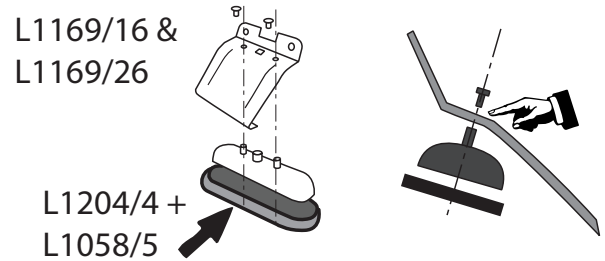
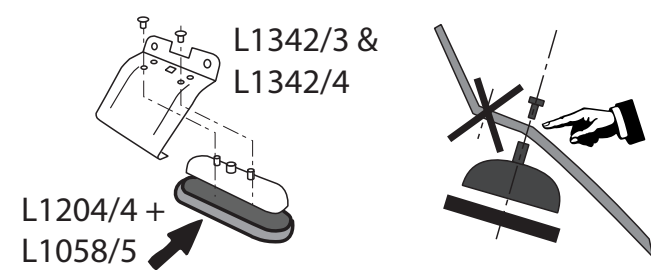

MOCSRR0AC010 cm 110
MOCSRR0AL006 cm 110

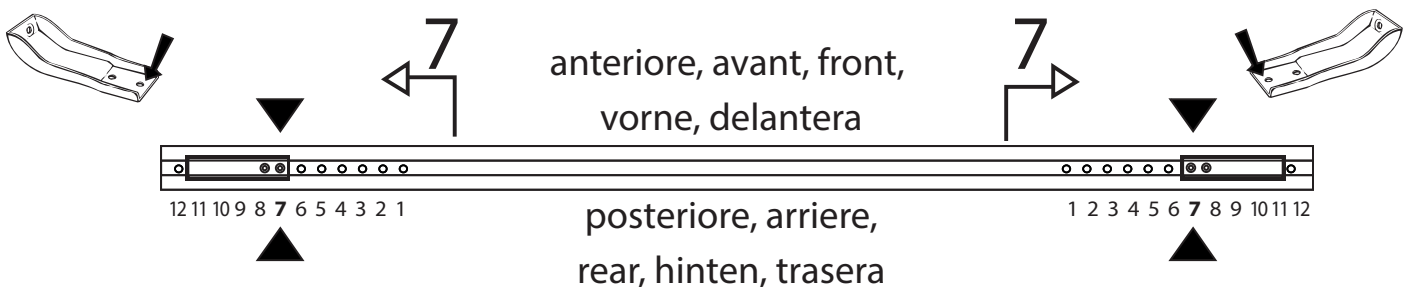

MOCSKT 306

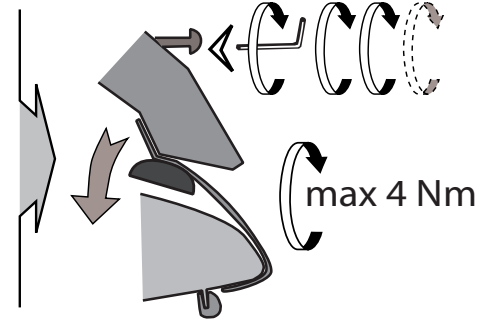
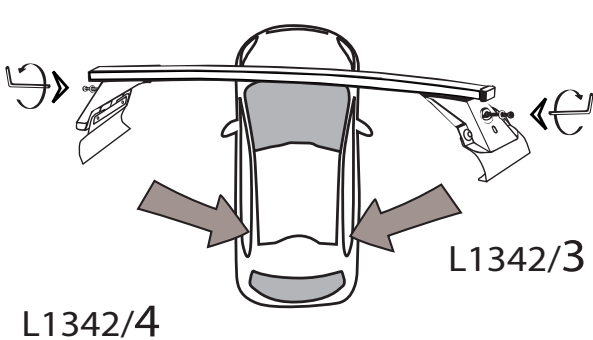
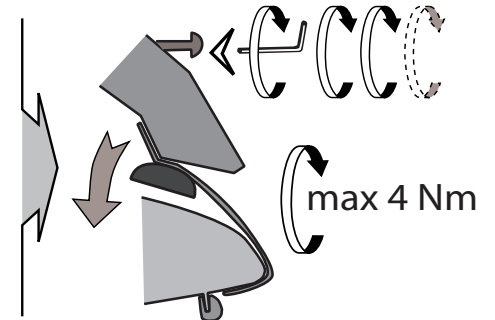
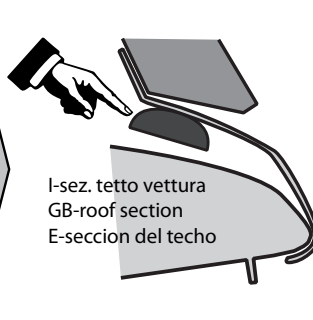
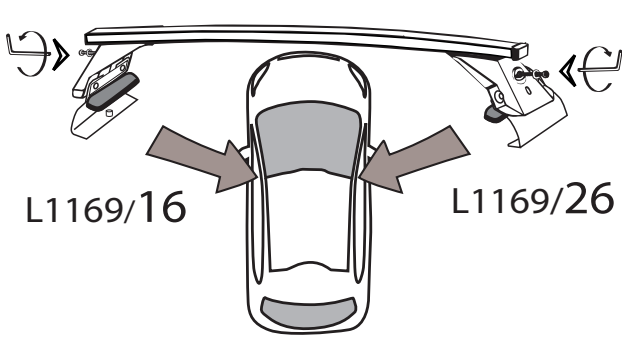
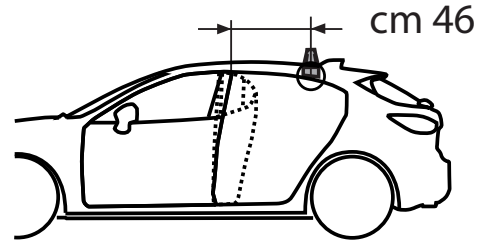
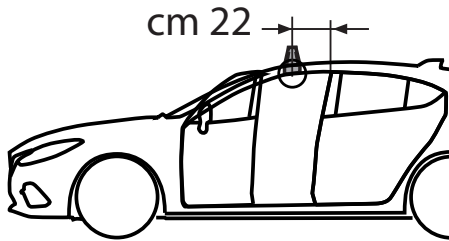
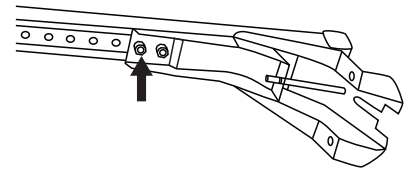
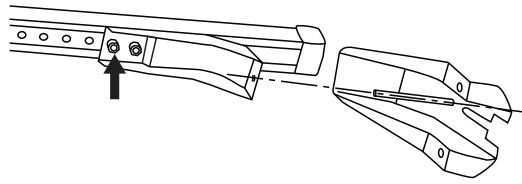
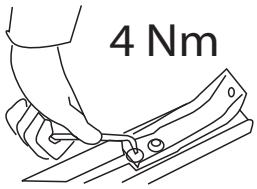

I - Per stringere, usare la chiave come indicato nel disegno. (Non si assumono responsabilità per danni causati dall'impiego di chiavi diverse da quella in dotazione al prodotto).
F - Pour serrer, utiliser la clé comme indique ci dessous.

GB - To tighten please use the wrench as per the drawing.
D - Zum Anziehen benutzen Sie bitte den Inbusschlüssel, nur wie auf dem Bild dargestellt.
E - Para el correcto ajuste, utilizar la llave fija tal y como se indica en la imagen

