









MAZDA CX-3 model 2015

MOCSKT 298

MOCSRR0AC010 cm 110

MOCSRR0AL006 cm 110

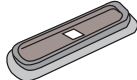

1 - L1342/3 ant. sx 	2 - L954 post. 	8 - RCVM6X9Q 
1 - L1342/4 ant. dx 	4 - L1204/4 	4 - RC20200026 
	4 - L1058/8 	1 - RCBR5 

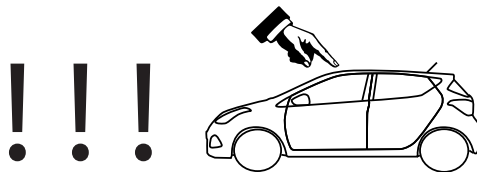
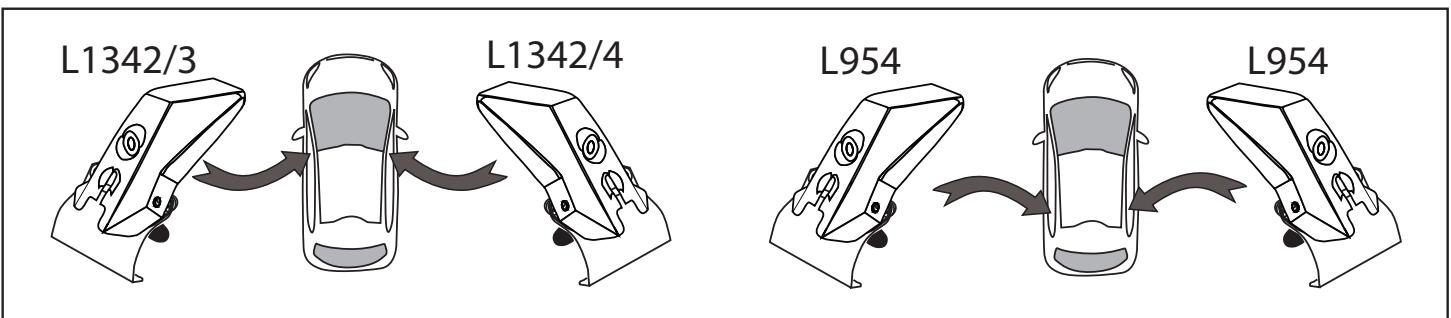
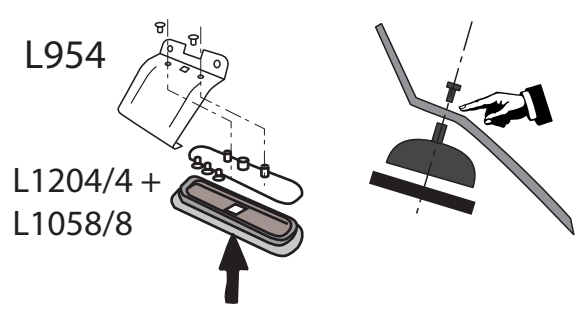
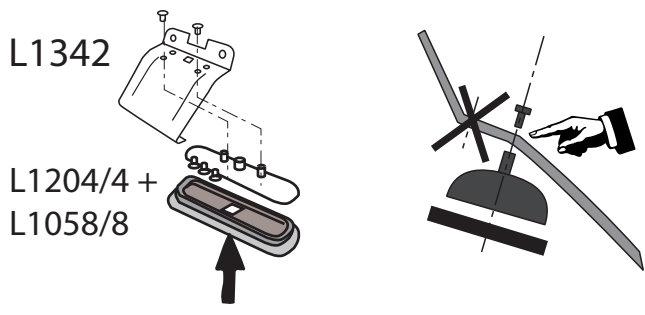

MOCSRR0AC010 cm 110
MOCSRR0AL006 cm 110

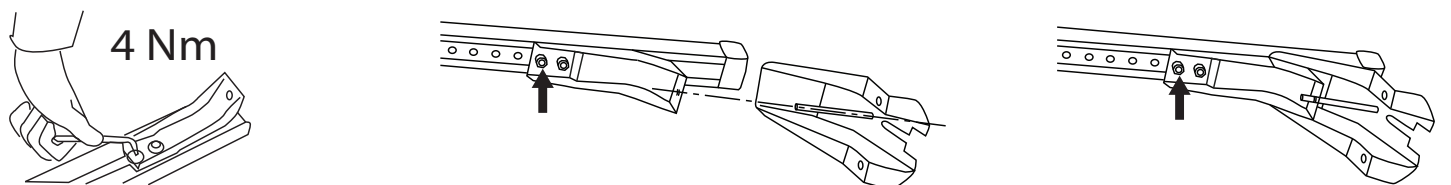
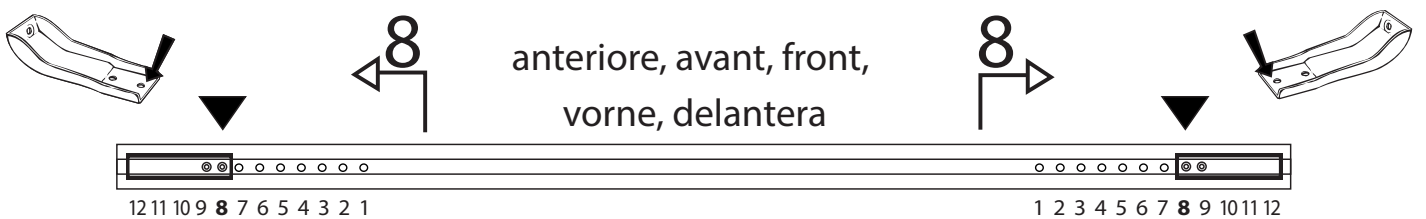

MOCSKT 298

!!!



MOCSRR0AC010 cm 110
MOCSRR0AL006 cm 110

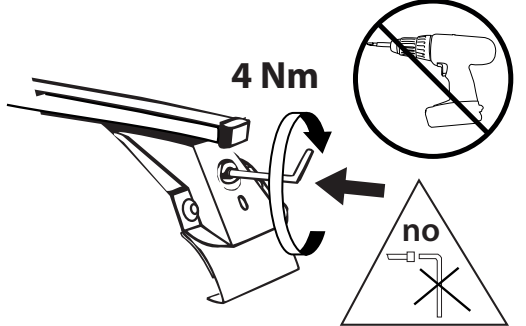
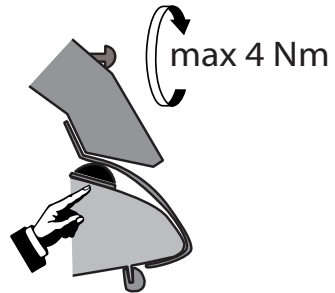
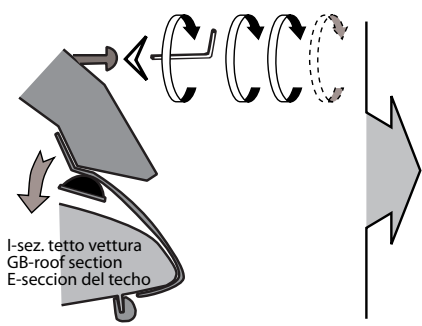
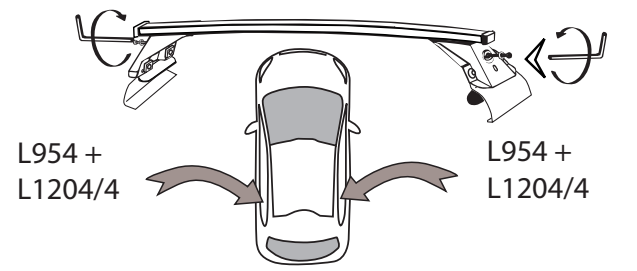
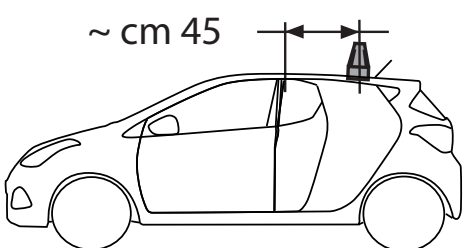
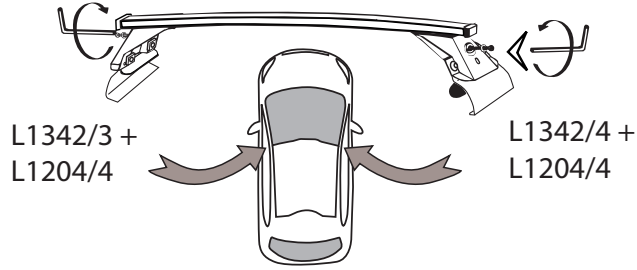
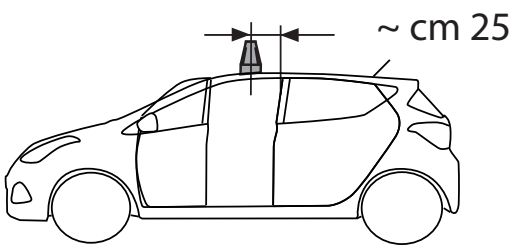
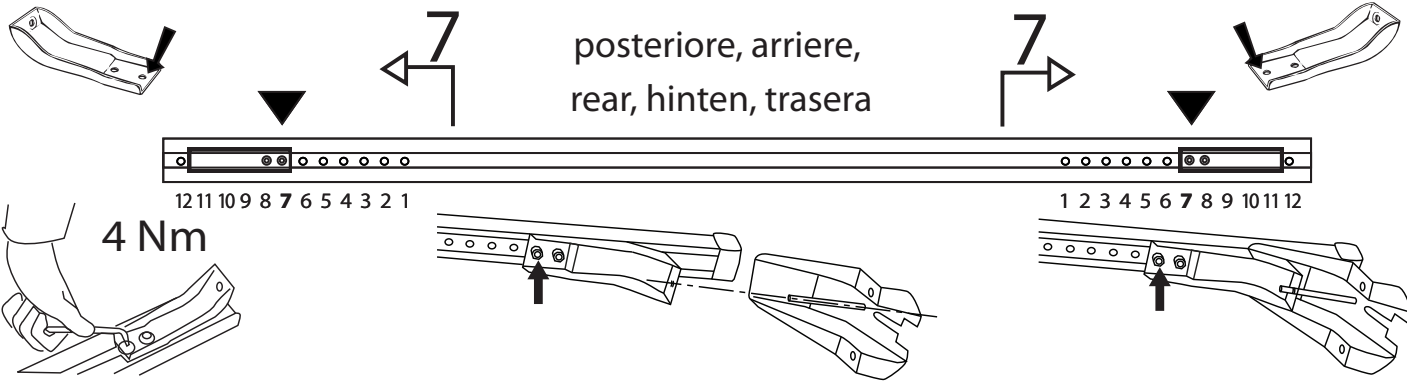

I - Per stringere, usare la chiave come indicato nel disegno. (Non si assumono responsabilità per danni causati dall'impiego di chiavi diverse da quella in dotazione al prodotto).
F - Pour serrer, utiliser la clé comme indiqué ci dessus.

GB - To tighten please use the wrench as per the drawing.
D - Zum Anziehen benutzen Sie bitte den Inbusschlüssel, nur wie auf dem Bild dargestellt.
E - Para el correcto ajuste, utilizar la llave fija tal y como se indica en la imagen