

MITSUBISHI Space Star 2014

MOCSKT 288



MOCSRROAC010 cm 110 MOCSRROAL006 cm 110

1 - L959/1 ant. sx		1 - L1115/2 post. sx		8 - RCVM6X9Q	
1 - L959/2 ant. dx		4 - L1204/4		4 - RC20200026	
1 - L1115/1 post. dx		4 - L1058/8		1 - RCBR5	

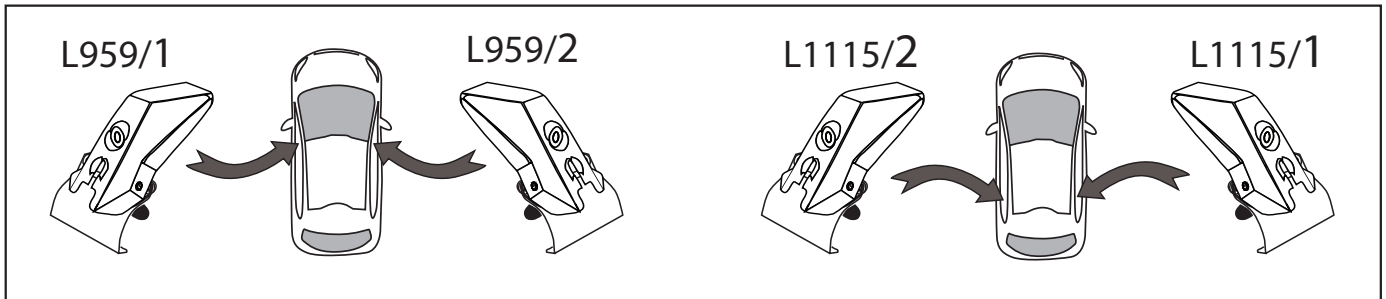
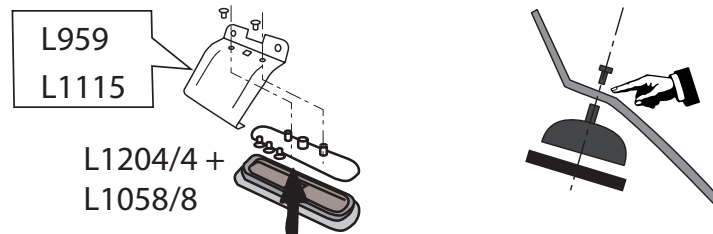

MOCSRROAC010 cm 110 MOCSRROAL006 cm 110

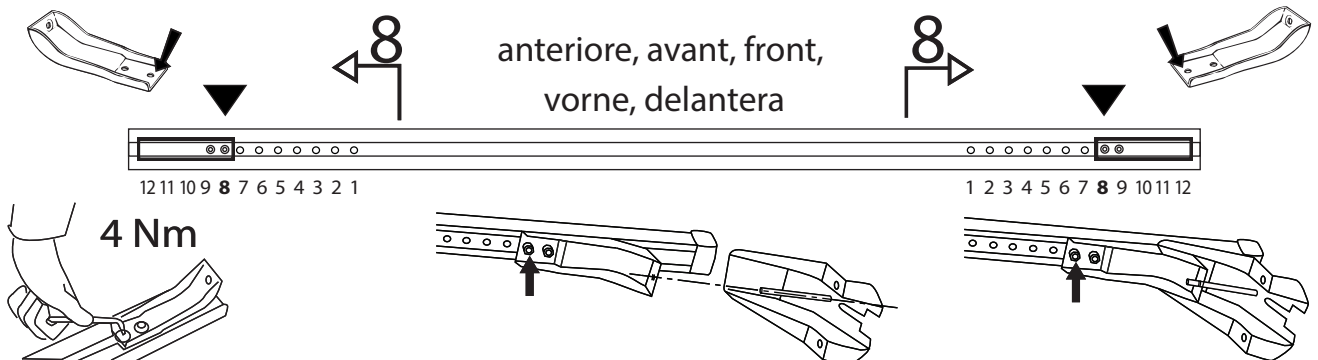

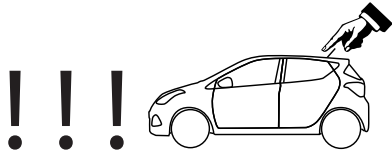

MOCSRR0AC010 cm 110
MOCSRR0AL006 cm 110

MOCSKT 288

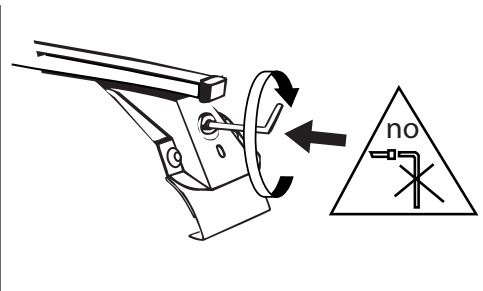
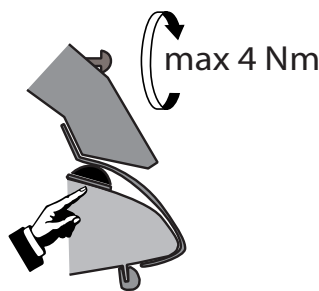
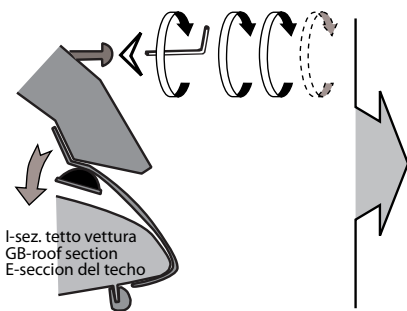
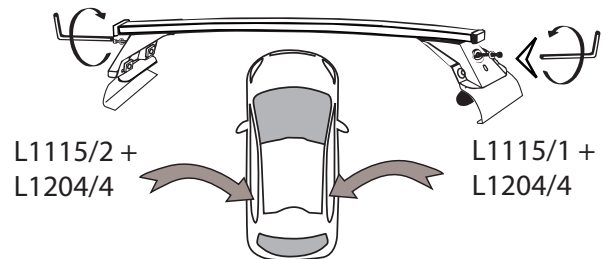
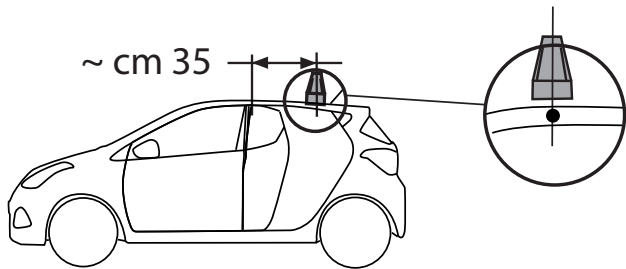
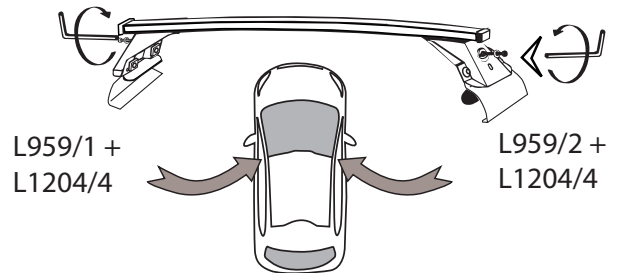
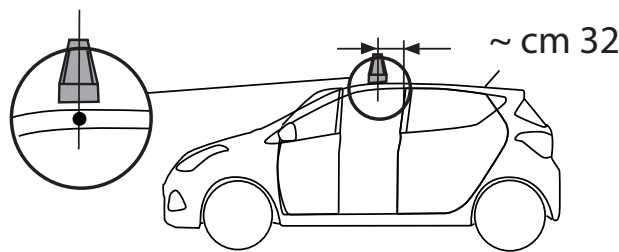
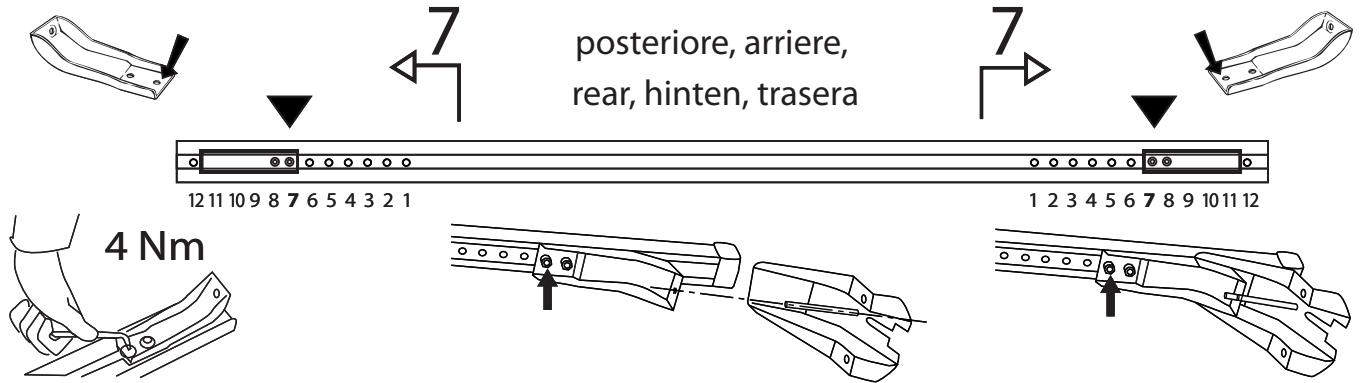

I - Per stringere, usare la chiave come indicato nel disegno.
 (Non si assumono responsabilità per danni causati dall'impiego di chiavi diverse da quella in dotazione al prodotto).
 F - Pour serrer, utiliser la clé comme indiqué ci dessus.

GB - To tighten please use the wrench as per the drawing.
 D - Zum Anziehen benutzen Sie bitte den Inbusschlüssel, nur wie auf dem Bild dargestellt.
 E - Para el correcto ajuste, utilizar la llave fija tal y como se indica en la imagen