









HYUNDAI iX35 2013 no rails

MOCSRR0AC011 cm 124

MOCSRR0AL007 cm 124

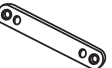

1 - L1273/3 ant. sx 	1 - L1045/35 post. dx 	4 - L1297/5 	8 - RCVM6X13Q 
1 - L1273/4 ant. dx 	1 - L1045/45 post. sx 	4 - L1204/4 	4 - RC20200026 
		4 - L1058/5 	1 - RCBR5 

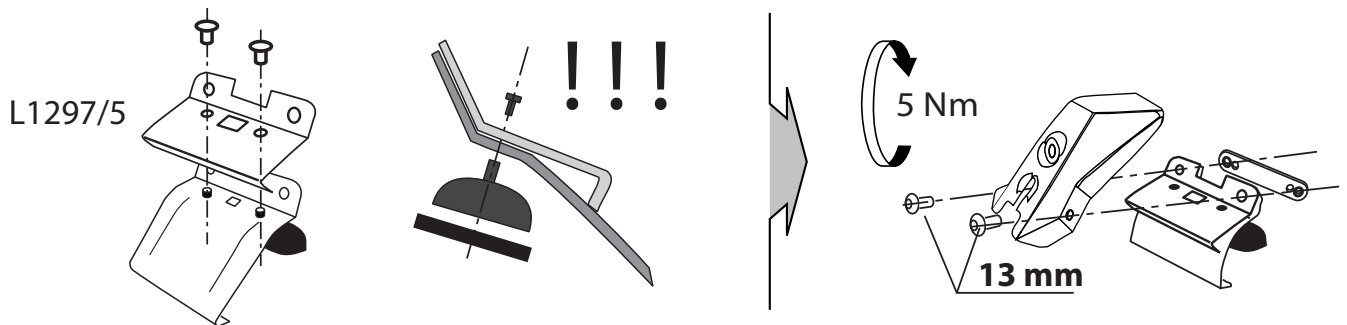
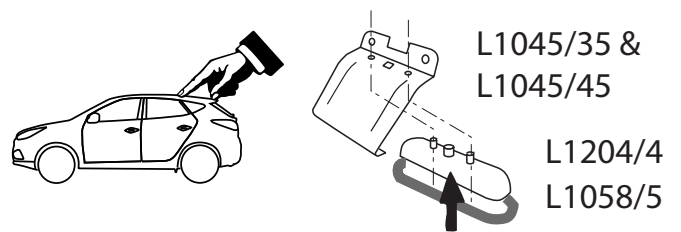
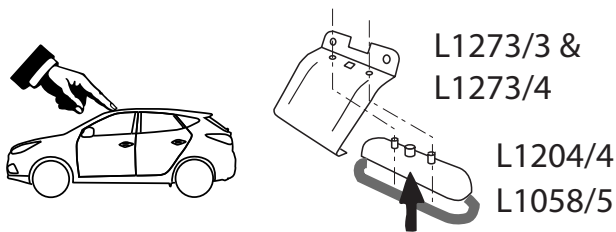

MOCSRR0AC011 cm 124 - MOCSRR0AL007 cm 124

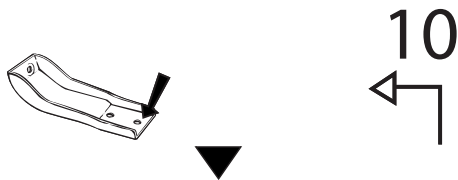

anteriore, avant, front,
vorne, delantera

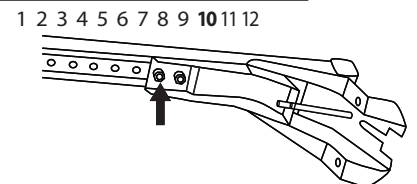
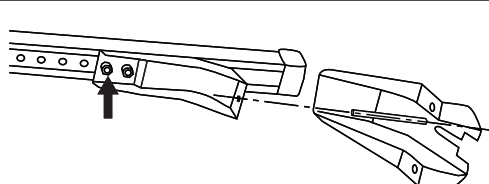
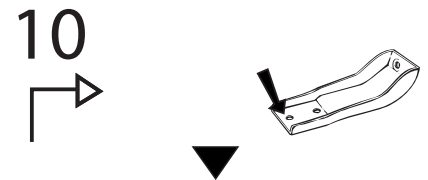

MOCSKT 271



MOCSRR0AC011 cm 124
MOCSRR0AL007 cm 124

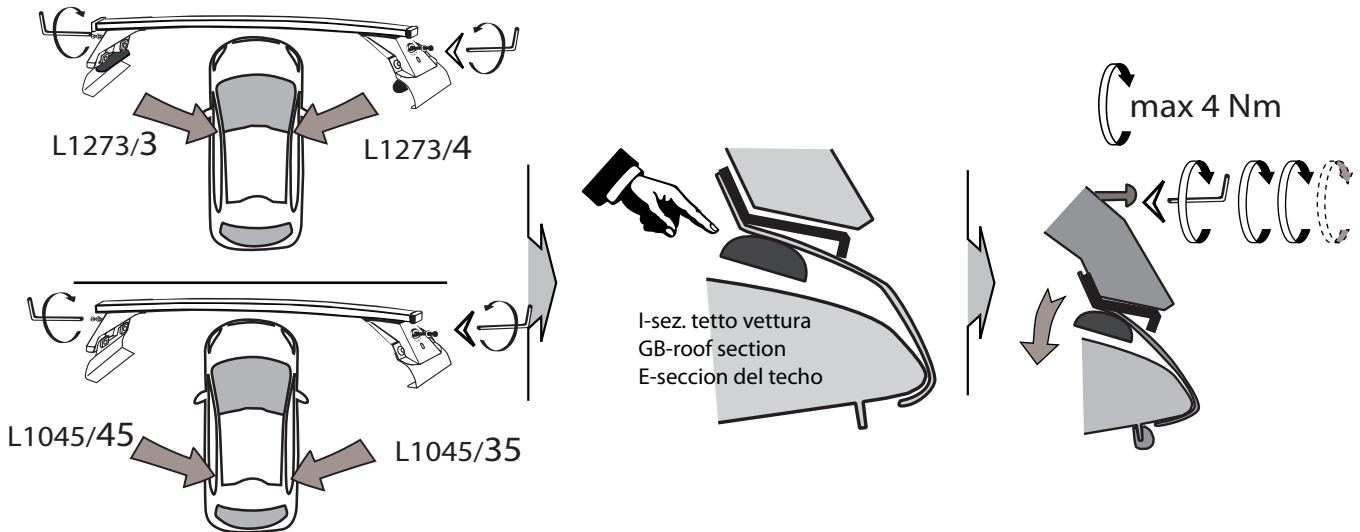
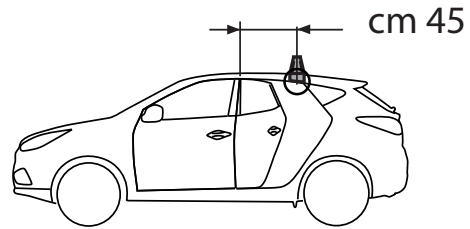
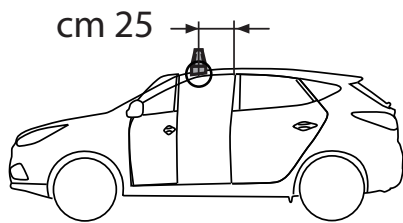
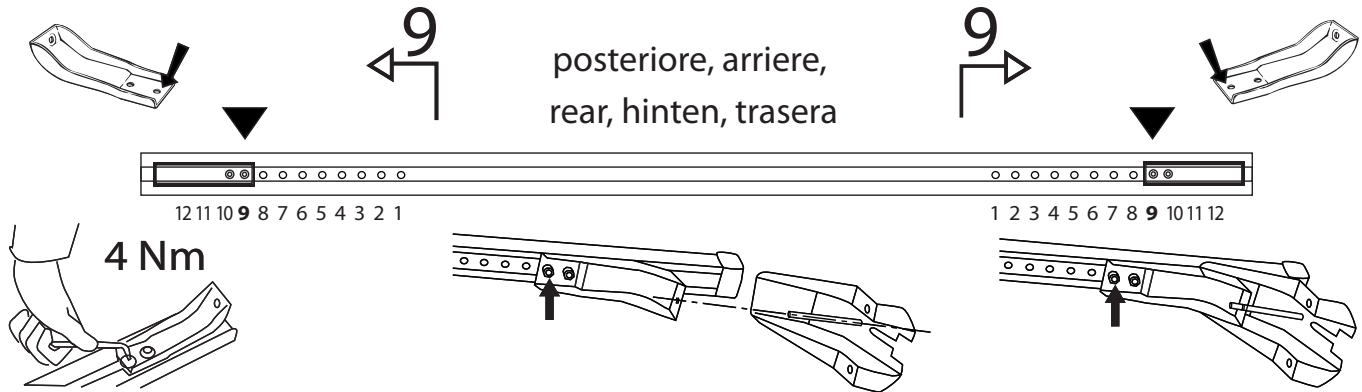

I - Per stringere, usare la chiave come indicato nel disegno. (Non si assumono responsabilità per danni causati dall'impiego di chiavi diverse da quella in dotazione al prodotto).
 F - Pour serrer, utiliser la clé comme indique ci dessous.

GB - To tighten please use the wrench as per the drawing.
 D - Zum Anziehen benutzen Sie bitte den Inbusschlüssel, nur wie auf dem Bild dargestellt.
 E - Para el correcto ajuste, utilizar la llave fija tal y como se indica en la imagen

