

CHEVROLET Malibu

berlina / sedan model 2012

MOCSKT 245

MOCSRR0AC011 cm 124

MOCSRR0AL007 cm 124



1 - L925/3 ant sx		1 - L1015/3 post dx		4 - RC1500/60		2 - RCVM6X9Q	
1 - L925/4 ant dx		1 - L1015/4 post sx		4 - RC20200026		6 - RCVM6X13Q	
2 - L1297/5		2 - RC20011935				1 - RCBR5	

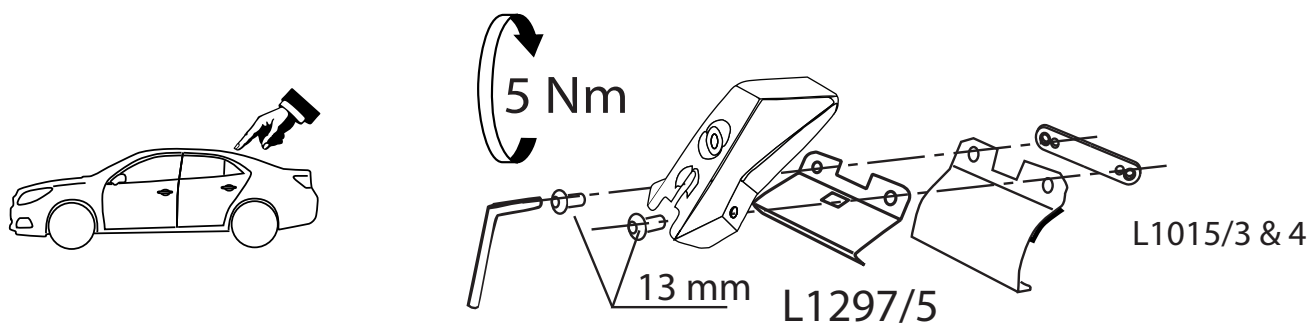
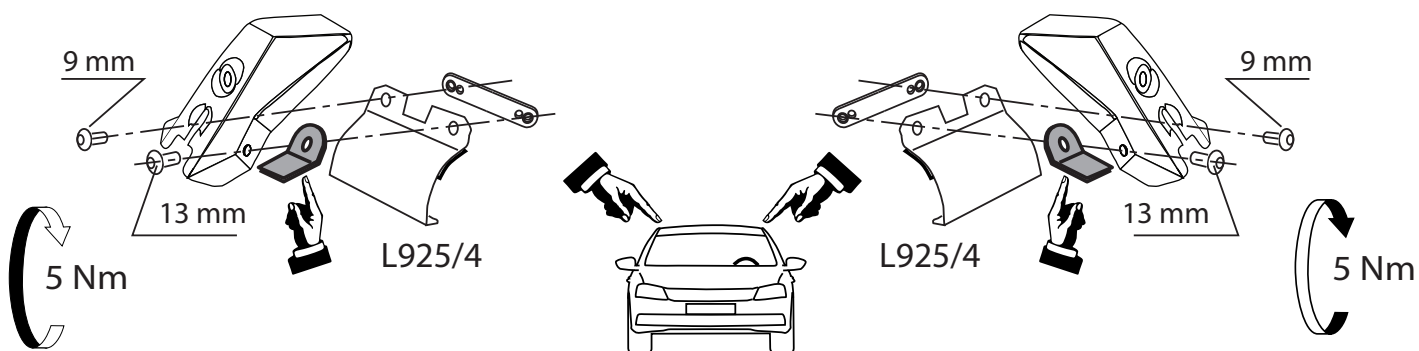
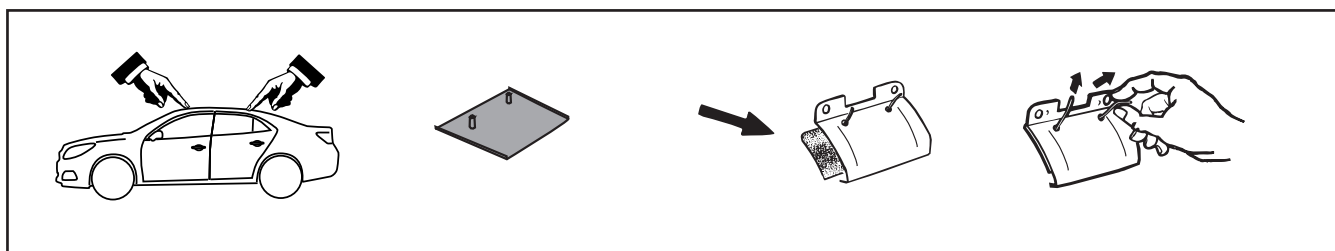

MOCSKT 245

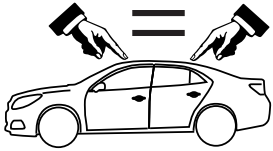

MOCSRR0AC011 cm 124
MOCSRR0AL007 cm 124

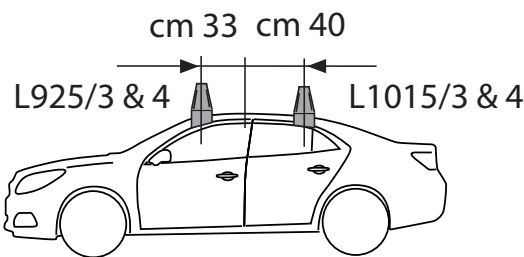
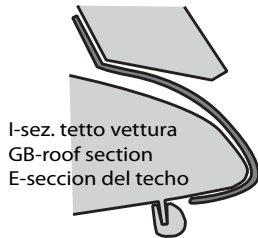
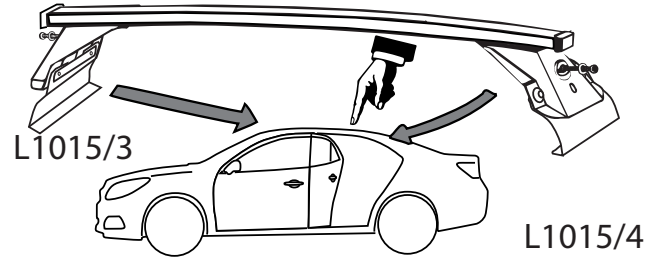
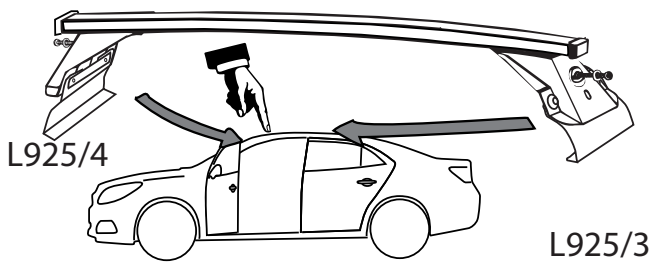
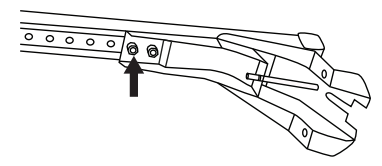
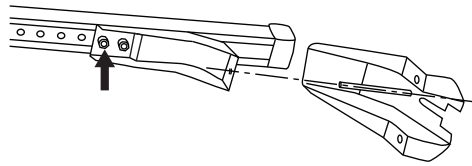
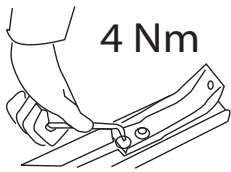
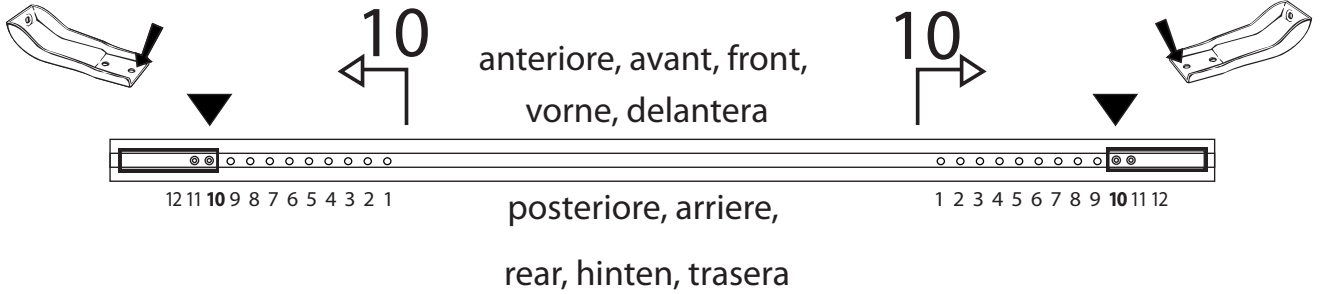

I - Per stringere, usare la chiave come indicato nel disegno. (Non si assumono responsabilità per danni causati dall'impiego di chiavi diverse da quella in dotazione al prodotto).

F - Pour serrer, utiliser la clé comme indique ci dessous.

GB - To tighten please use the wrench as per the drawing.

D - Zum Anziehen benutzen Sie bitte den Inbusschlüssel, nur wie auf dem Bild dargestellt.

E - Para el correcto ajuste, utilizar la llave fija tal y como se indica en la imagen

