

KIA Rio III 5 porte/doors model 2011

KIA Rio III 3 porte/doors model 2012

MOCSKT 206



MOCSRR0AC010 cm 110

MOCSRR0AL006 cm 110

1 - L925/3 ant sx		1 - L1045/3 post dx		2 - L1204/4		6 - RCVM6X9Q	
1 - L925/4 ant dx		1 - L1045/4 post sx		2 - L1058/5		2 - RCVM6X13Q	
		1 - inseritore		2 - RC1500/60		4 - RC20200026	
				2 - RC20011935		1 - RCBR5	

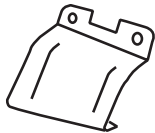

L925/3 ant sx
L925/4 ant dx

I-montare le guarnizioni
GB-fit the gaskets
E- montar las juntas

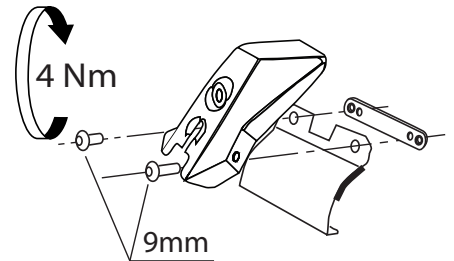

MOCSRR0AC010 cm 110

MOCSRR0AL006 cm 110

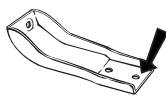

anteriore, avant, front,
vorne, delantera

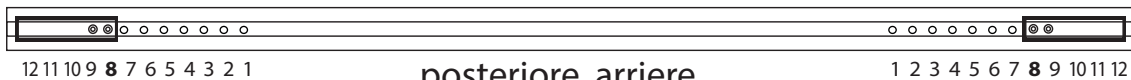
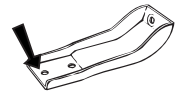

12 11 10 9 8 7 6 5 4 3 2 1

posteriore, arriere,
rear, hinten, trasera

1 2 3 4 5 6 7 8 9 10 11 12

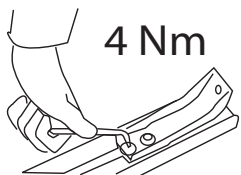

4 Nm

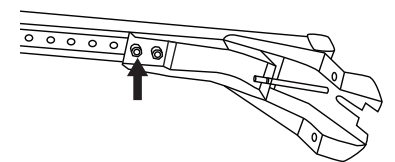
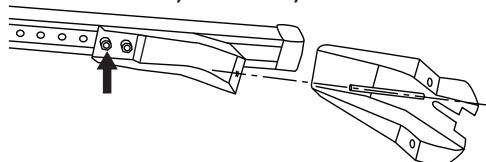

L925/4

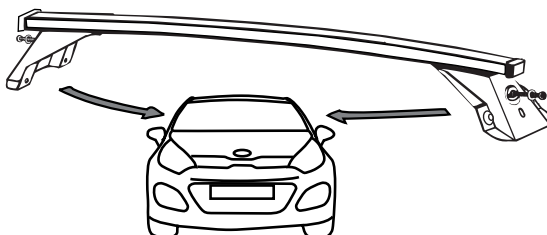

L925/3

I-sez. tetto vettura
GB-roof section
E-seccion del techo



MOCSKT 206

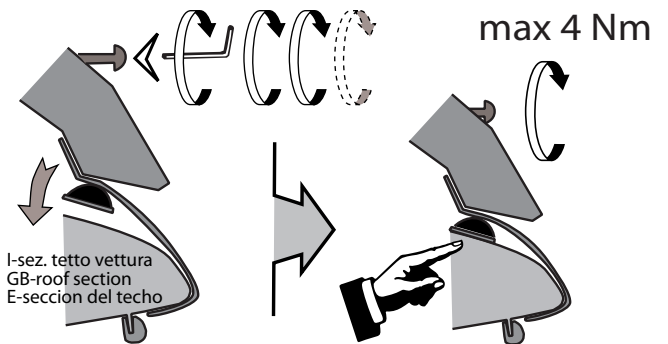
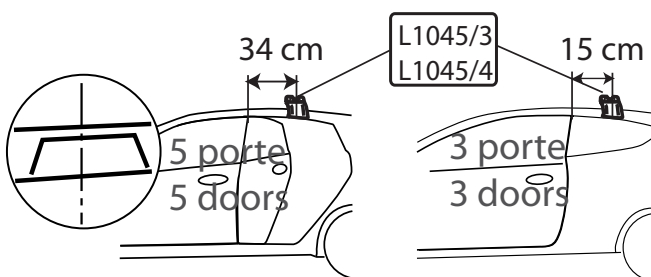
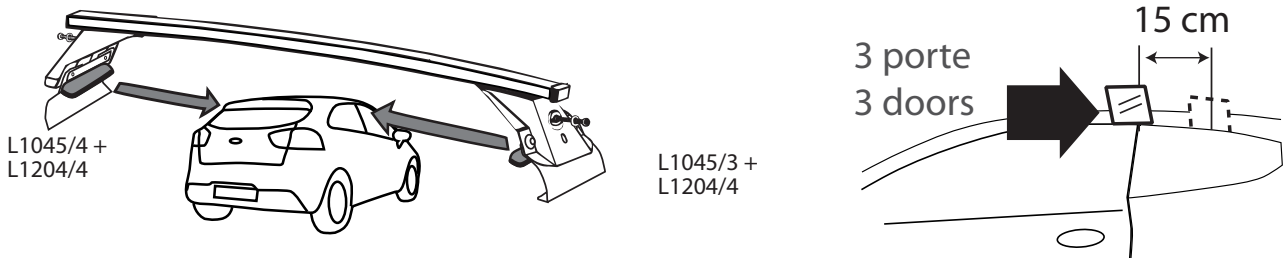
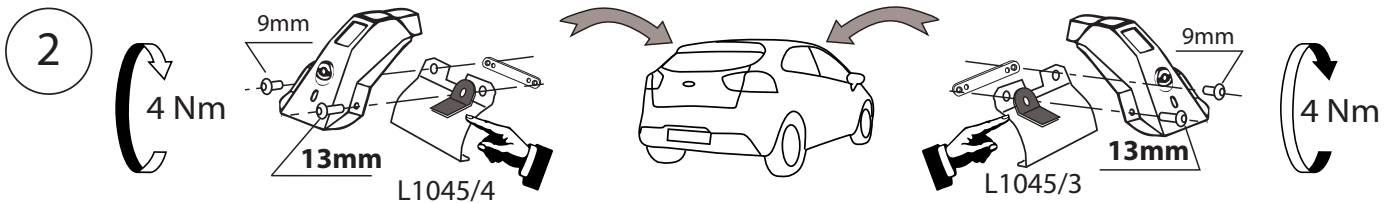
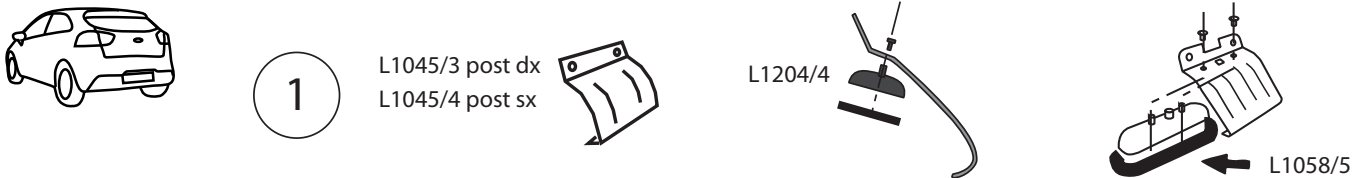
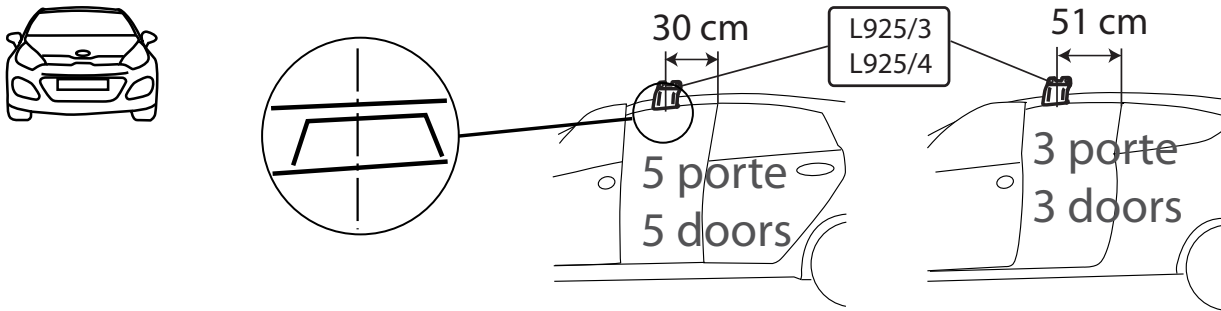

I - Per stringere, usare la chiave come indicato nel disegno. (Non si assumono responsabilità per danni causati dall'impiego di chiavi diverse da quella in dotazione al prodotto).

F - Pour serrer, utiliser la clé comme indiqué ci dessous.

GB - For tightening, please use the wrench as per the drawing.

D - Zum Anziehen benutzen Sie bitte den Inbusschlüssel, nur wie auf dem Bild dargestellt.

E - Para el correcto ajuste, utilizar la llave fija tal y como se indica en la imagen.

max 4 Nm

