







FIAT Freemont no rails 2011

MOSKOT 202

MOSKRR0AC011 cm 124

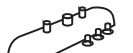
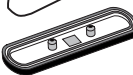
MOSKRR0AL007 cm 124



<p>componenti:</p> <p>2 - L848/3 ant </p> <p>2 - L1108/3 post </p>	<p>2 - L1061/4 </p> <p>2 - L1058/6 </p> <p>2 - RC1500/95 </p>	<p>8 - RCVM6X9Q </p> <p>4 - RC20200026 </p> <p>1 - RCBR5 </p>
--	--	--

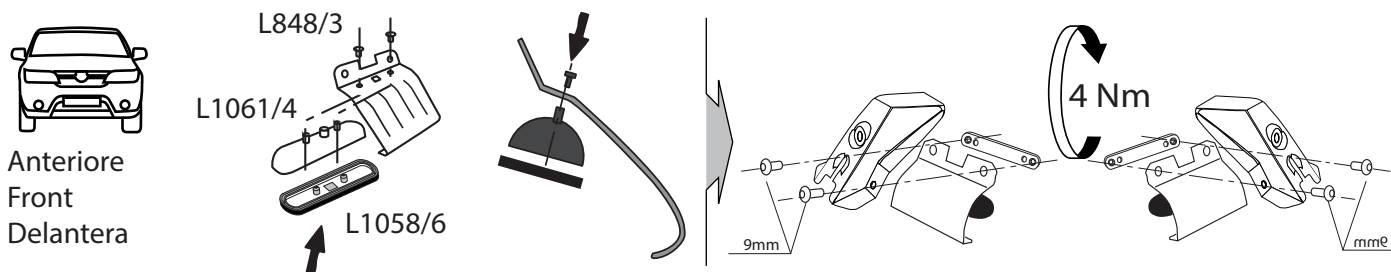

MOSKRR0AC011 cm 124
MOSKRR0AL007 cm 124

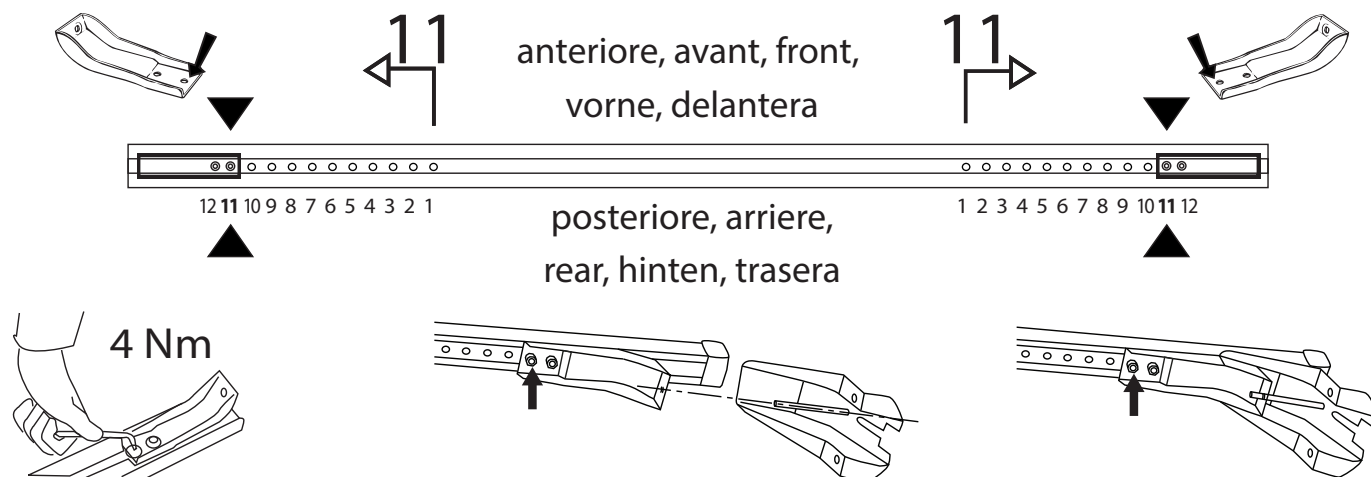

I-montare la barra anteriore
GB- fit the front bar
E- ajustar la barra frontal

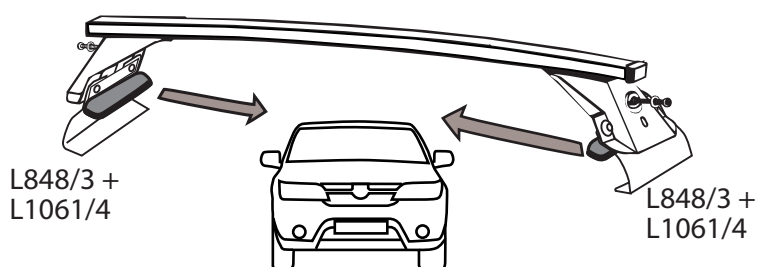

MOCSKT 202

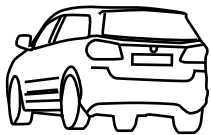
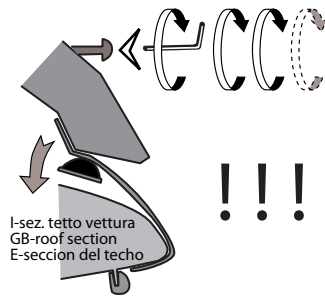
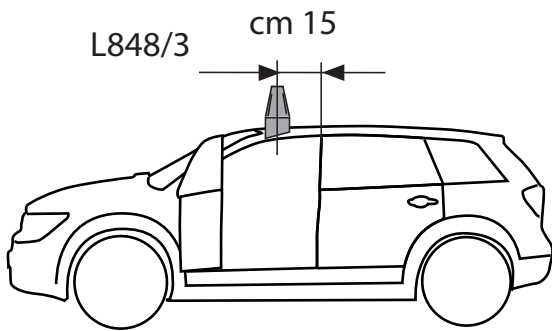

Posteriore
Rear
Trasera



L1108/3

I-montare le guarnizioni
GB-fit the gaskets
E- montar las juntas

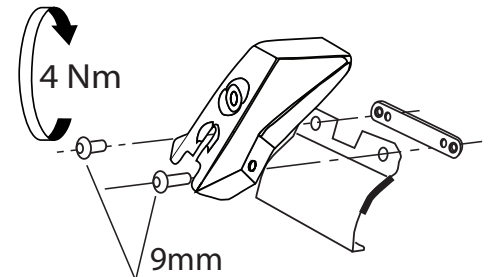
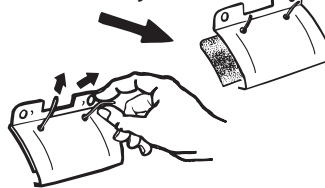

I-montare la barra posteriore
GB-fit the rear bar
E- ajustar la barra trasera

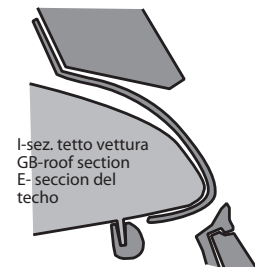
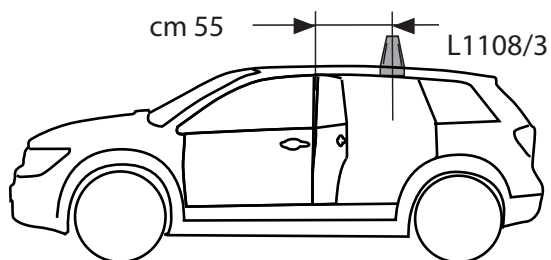
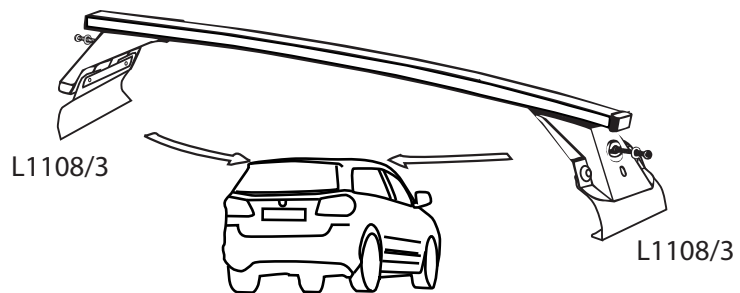

I - Per stringere, usare la chiave come indicato nel disegno. (Non si assumono responsabilità per danni causati dall'impiego di chiavi diverse da quella in dotazione al prodotto).
F - Pour serrer, utiliser la clé comme indique ci dessous.

GB - To tighten please use the wrench as per the drawing.
D - Zum Anziehen benutzen Sie bitte den Inbusschlüssel, nur wie auf dem Bild dargestellt.
E - Para el correcto ajuste, utilizar la llave fija tal y como se indica en la imagen

