

# VOLKSWAGEN Jetta VI model 2011



**MOCSRR0AC010 cm 110**

**MOCSRR0AL006 cm 110**

componenti:				
1 - L953/3 ant sx		1 - L1215/1 post dx		2 - RC1500/60
1 - L953/4 ant dx		1 - L1215/2 post sx		8 - RCVM6X9Q
		2 - RC1500/90		2 - RCVM6X12Q
				4 - RC20200026
				1 - RCBR5
				1 - RCBR4

I-montare le guarnizioni  
GB-fit the gaskets  
E- montar las juntas

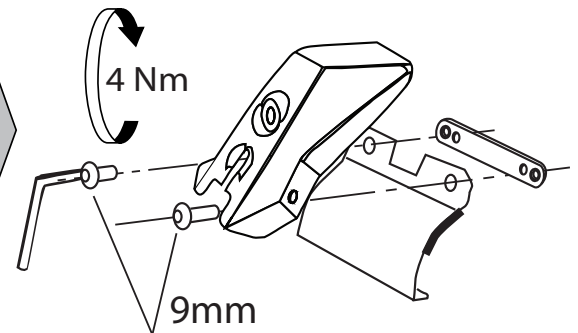
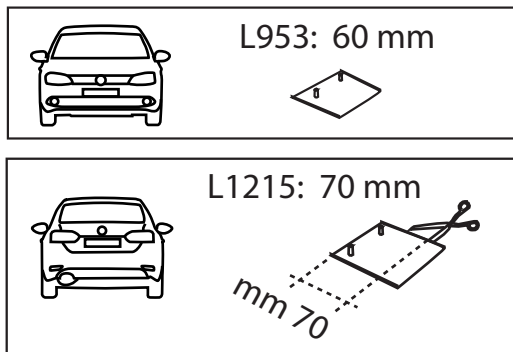
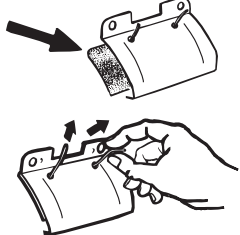

**MOCSRR0AC010 cm 110**  
**MOCSRR0AL006 cm 110**

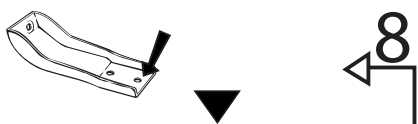

anteriore, avant, front,  
vorne, delantera

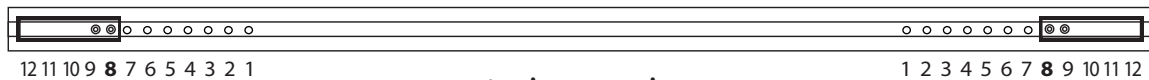
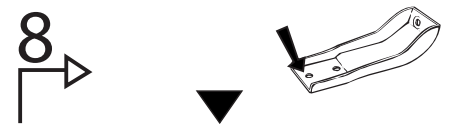

posteriore, arriere,  
rear, hinten, trasera

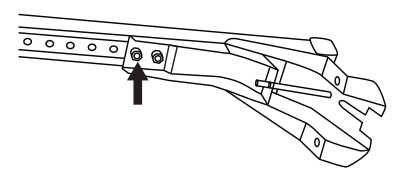
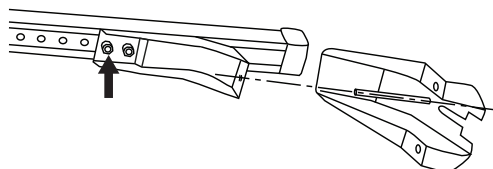
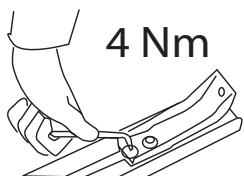

# MOCSKT 182

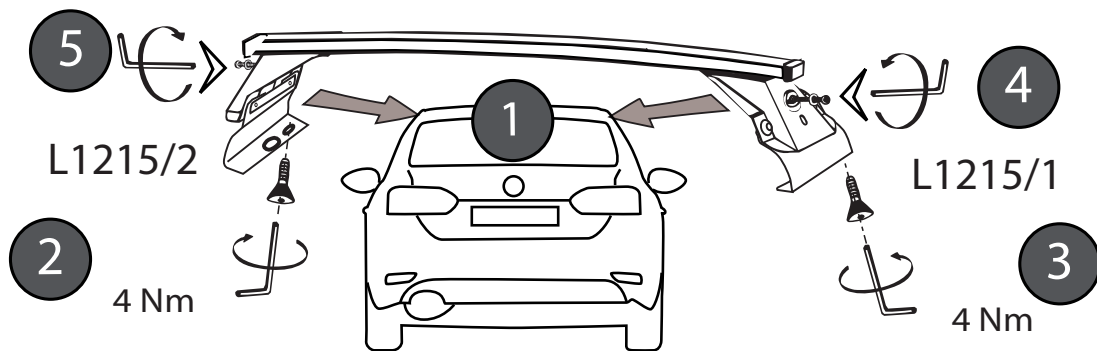
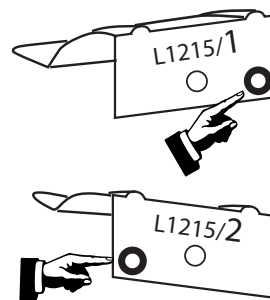
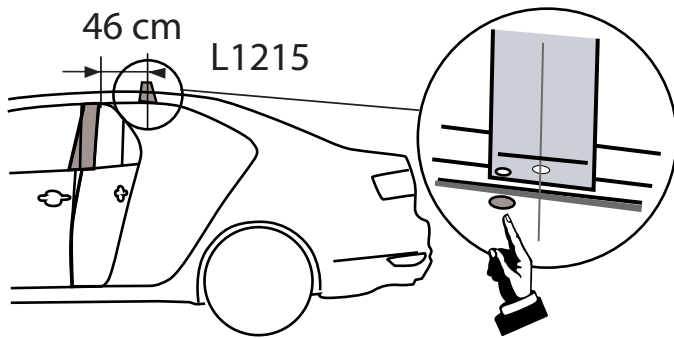
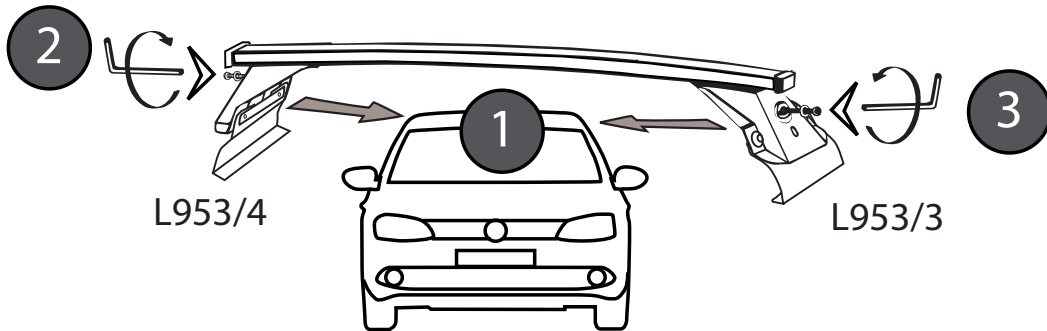
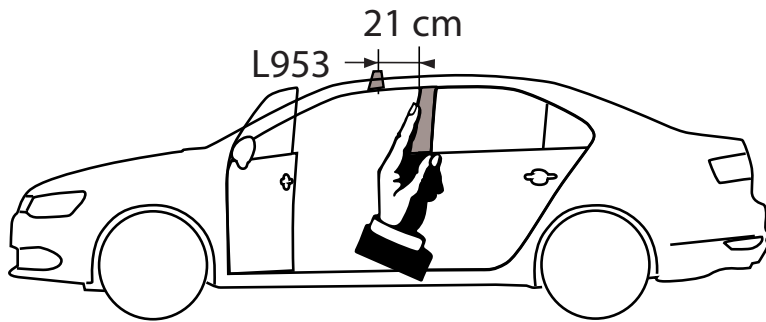

I - Per stringere, usare la chiave come indicato nel disegno. (Non si assumono responsabilità per danni causati dall'impiego di chiavi diverse da quella in dotazione al prodotto).

F - Pour serrer, utiliser la clé comme indique ci dessous.

GB - To tighten please use the wrench as per the drawing.

D - Zum Anziehen benutzen Sie bitte den Inbusschlüssel, nur wie auf dem Bild dargestellt.

E - Para el correcto ajuste, utilizar la llave fija tal y como se indica en la imagen

