







MOC SRR0AC010 cm 110

MOC SRR0AL006 cm 110

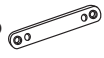
componenti:

1 - L859/1 ant. sx		1 - L1198/1 post. dx		4 - RC1500/60		4 - RC20200026	
1 - L859/2 ant. dx		1 - L1198/2 post. sx		8 - RCVM6X9Q		1 - RCBR5	

- I - montare le guarnizioni
- F - monter les joints
- GB - fit the gaskets
- D - Die Dichtungen einsetzen
- E - montar las juntas



- I - montare gli attacchi anteriori
- F - monter les griffer avant
- GB - fit the front clamps
- D - Die vorne Klammern einsetzen
- E - ajustar las pletinas delantera

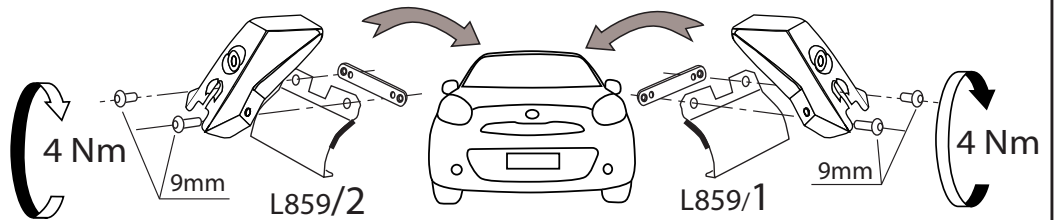

- I - montare gli attacchi posteriori
- F - monter les griffer arrière
- GB - fit the rear clamps
- D - Die hinten Klammern einsetzen
- E - ajustar las pletinas trasera.

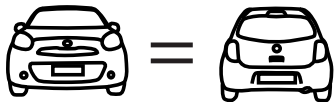
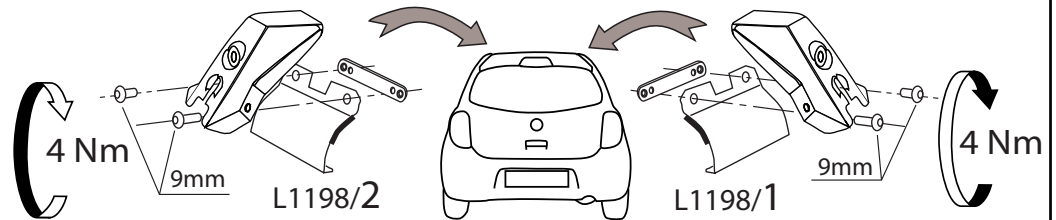

MOC SRR0AC010 cm 110
MOC SRR0AL006 cm 110

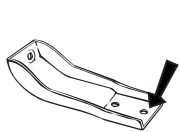

anteriore, avant, front,
vorne, delantera

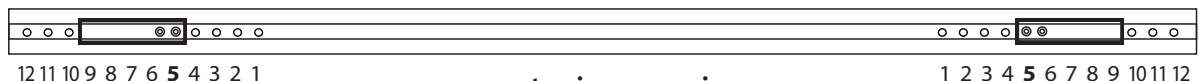
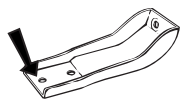

posteriore, arriere,
rear, hinten, trasera

MOCSKT 180

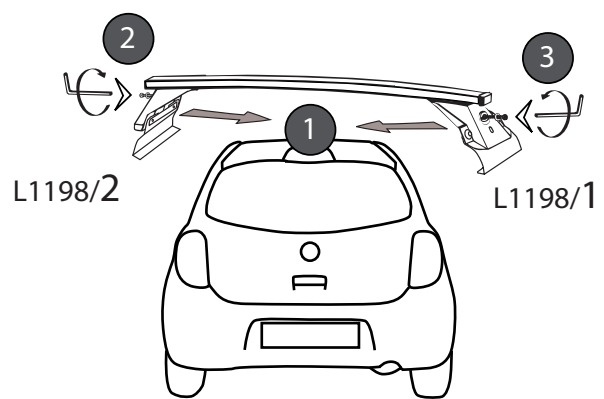
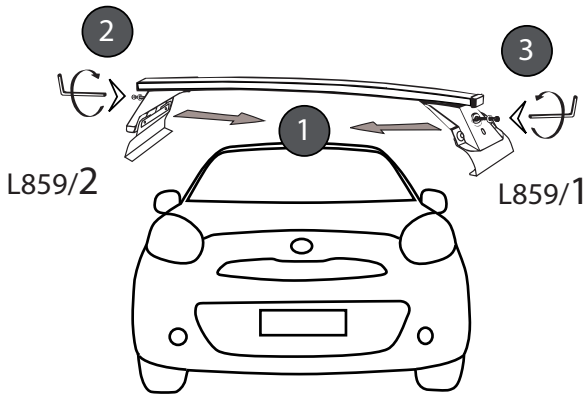
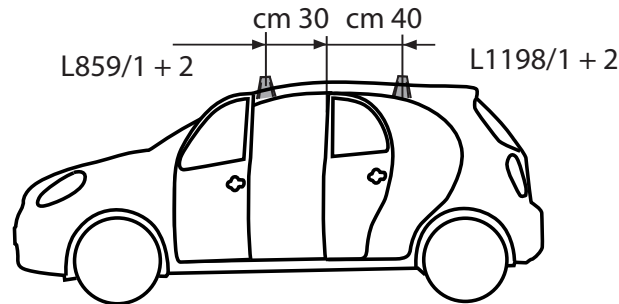
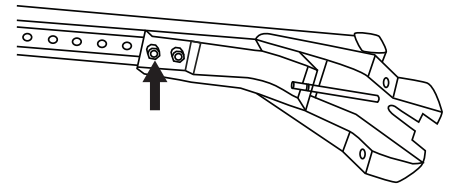
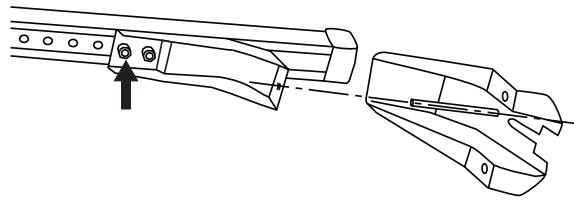
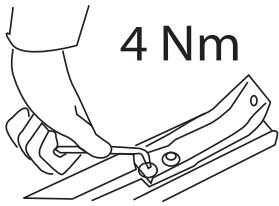

I - Per stringere, usare la chiave come indicato nel disegno. (Non si assumono responsabilità per danni causati dall'impiego di chiavi diverse da quella in dotazione al prodotto).

F - Pour serrer, utiliser la clé comme indique ci a coté.

GB - To tighten please use the wrench as per the drawing.

D - Zum Anziehen benutzen Sie bitte den Inbusschlüssel, nur wie auf dem Bild dargestellt.

E - Para el correcto ajuste, utilizar la llave fija tal y como se indica en la imagen

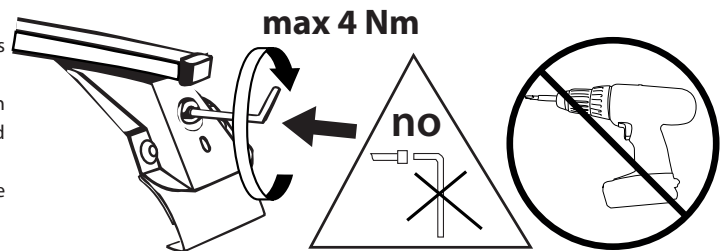

Ⓛ Si raccomanda, dopo il montaggio e periodicamente di verificare il fissaggio. La ditta non si assume responsabilità per eventuali danni riportati da persone o cose dovuti al cattivo impiego dei suoi prodotti.

ⓕ On recommande, après le montage et périodiquement de vérifier le fixation. La maison décline toutes responsabilités pour éventuels dommages dus au mauvais emploi de ses produits.

ⓖB We recommend after assembly and periodically to verify the fixing. The firm don't take responsibility for eventual damages or injury due to the bad use of his products.

ⓓ Es empfiehlt sich, dass ab und zu die richtige Befestigung überwacht werden. Unsere Firma haftet nicht für möglichen Schade zu Personne und Sachen wegen der unfähigen Anwendung unserer Erzeugnisse.

ⓔ Se recomienda verificar la sujeción periódicamente y después de cada montaje. La empresa no se hace responsable de los daños que se puedan ocasionar como consecuencia del mal uso de nuestros productos.

