

BMW serie 5 Touring 2010
no railing

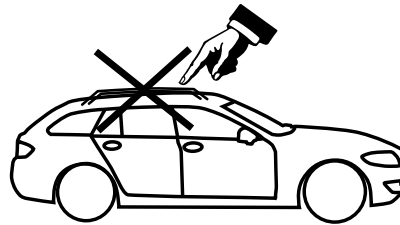

MOSKOT 173



MOSKOTR0AC011 cm 124
MOSKOTR0AL007 cm 124

1 - L1148/1 ant. sx		4 - L1204/4		8 - RCVM6X9Q	
1 - L1148/2 ant. dx		4 - L1058/5		4 - RC20200026	
2 - L799/3 post.				1 - RCBR5	

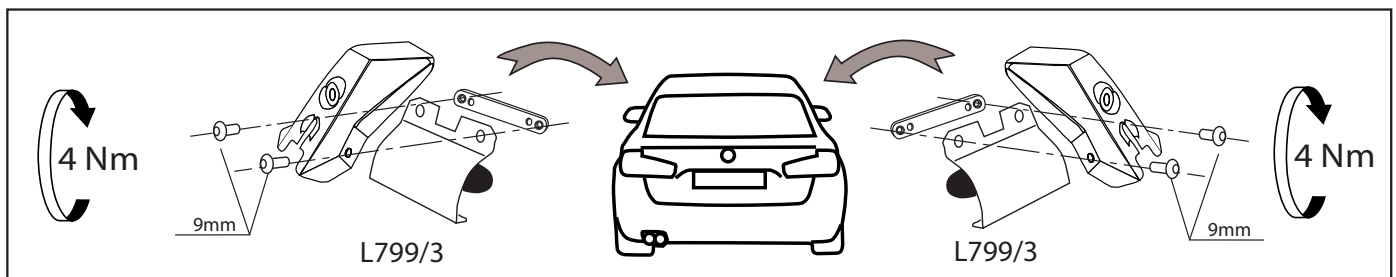
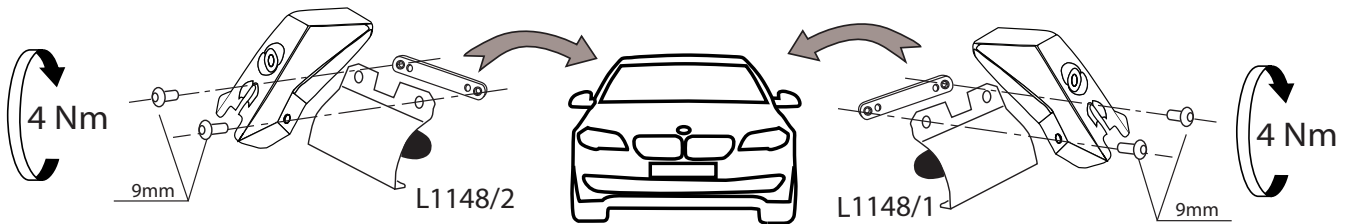
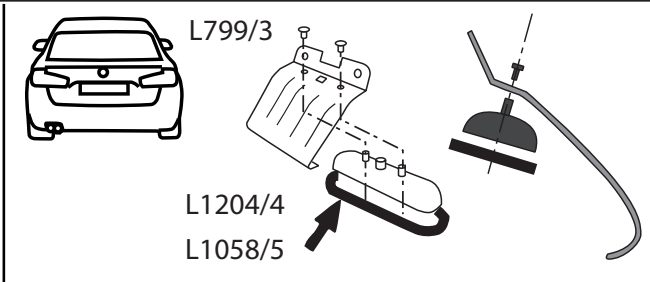
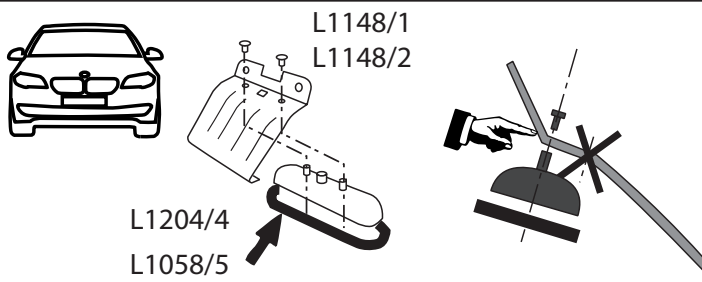

MOSKOTR0AC011 cm 124
MOSKOTR0AL007 cm 124

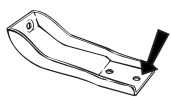

anteriore, avant, front,
vorne, delantera

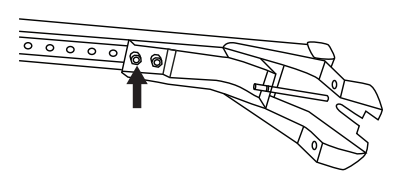
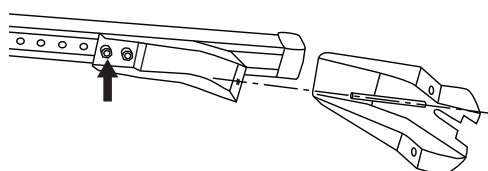
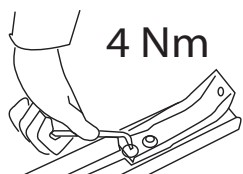
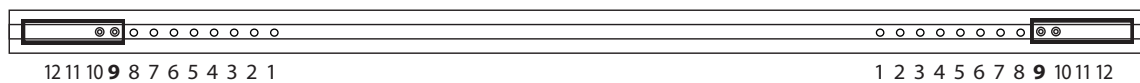
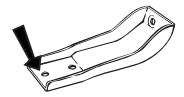

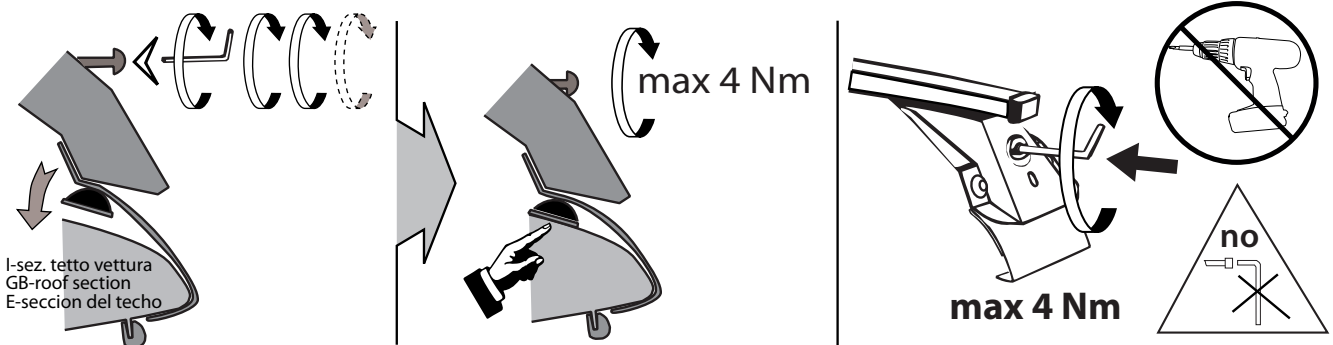
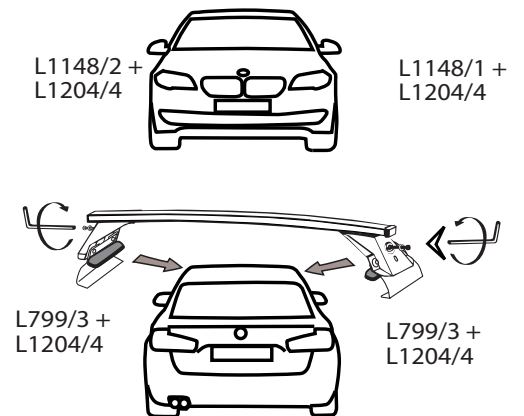
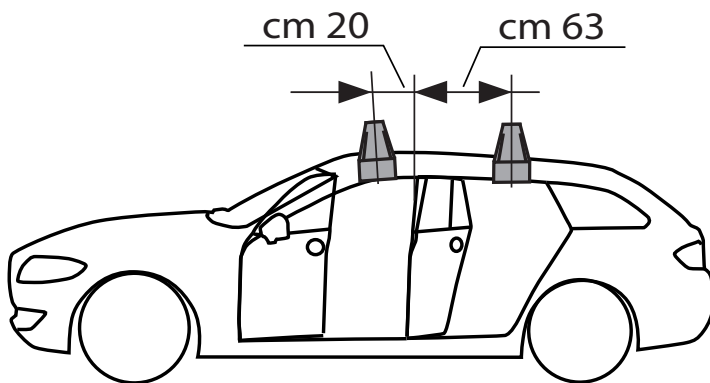
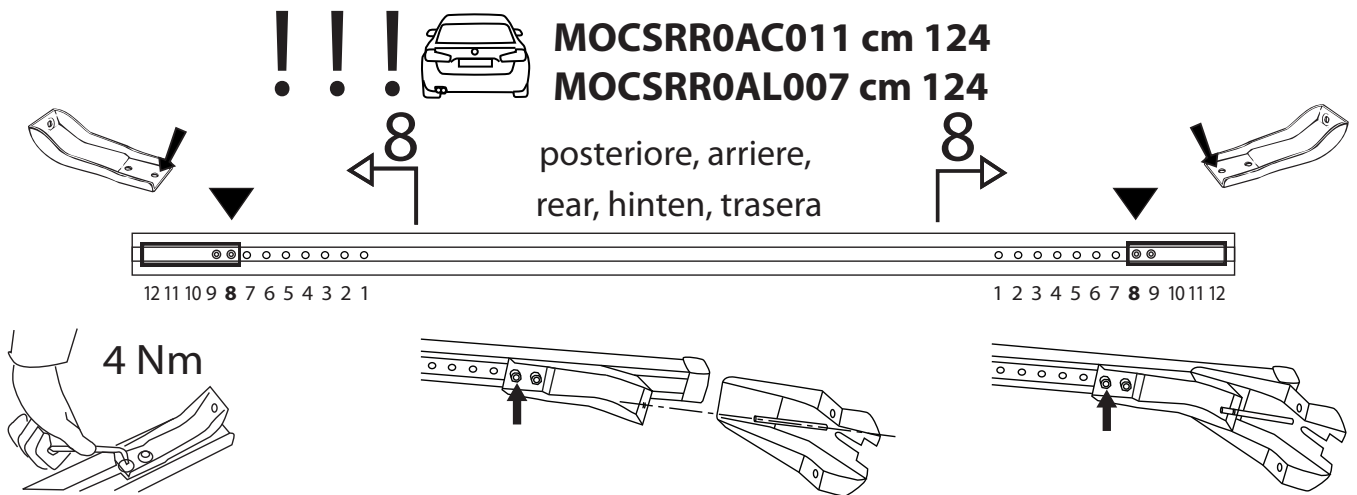

I - Per stringere, usare la chiave come indicato nel disegno. (Non si assumono responsabilità per danni causati dall'impiego di chiavi diverse da quella in dotazione al prodotto).

F - Pour serrer, utiliser la clé comme indique ci dessous.

GB - To tighten please use the wrench as per the drawing.

D - Zum Anziehen benutzen Sie bitte den Inbusschlüssel, nur wie auf dem Bild dargestellt.

E - Para el correcto ajuste, utilizar la llave fija tal y como se indica en la imagen