

Citroen C1 3 porte modello 2005
 Peugeot 107 3 porte modello 2005
 Toyota Aygo 3 porte modello 2005

MOCSKT 041



MOCSRR0AC010 cm 110

MOCSRR0AL006 cm 110

1 - L1112/1 ant. sx		2 - L1112/3 post.		2 - L1061/4		4 - RCVM6X9Q	
1 - L1112/2 ant. dx		2 - L1297/5		2 - L1058/7		4 - RC20200026	
		2 - RC1500/60		4 - RCVM6X13Q		1 - RCBR5	

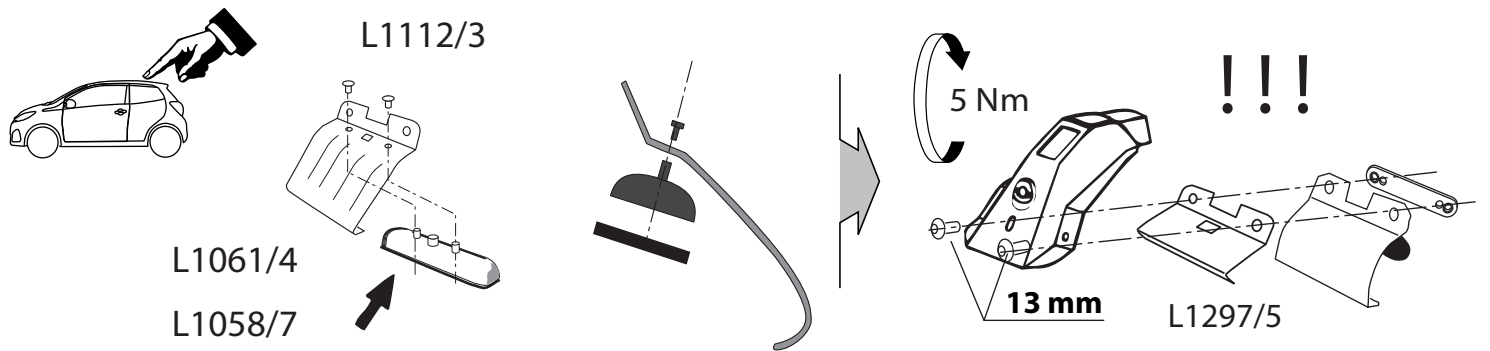

!!!



MOCSRR0AC010 cm 110

MOCSRR0AL006 cm 110



anteriore, avant, front,
 vorne, delantera

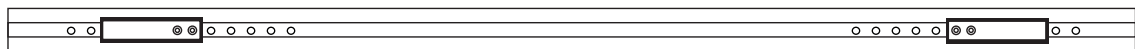
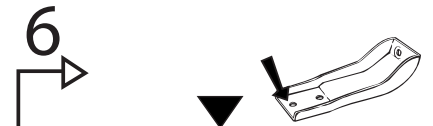

12 11 10 9 8 7 6 5 4 3 2 1

1 2 3 4 5 6 7 8 9 10 11 12

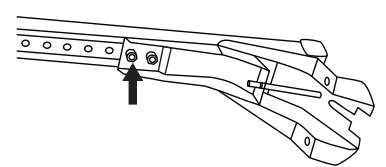
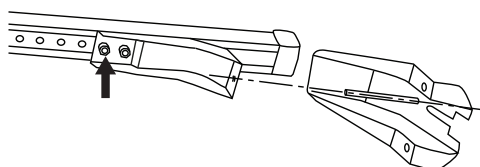
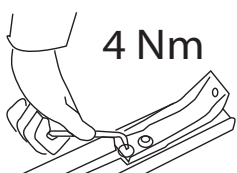

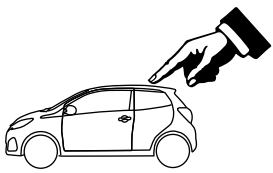

MOCSRR0AC010 cm 110
MOCSRR0AL006 cm 110

MOCSKT 041

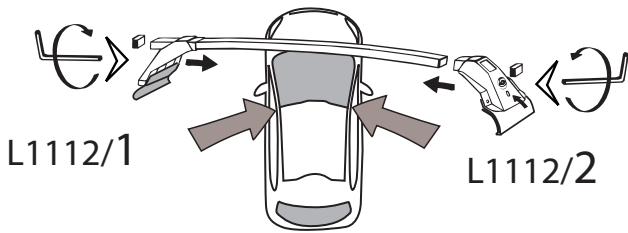
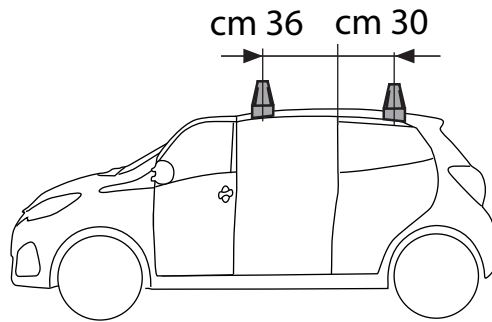
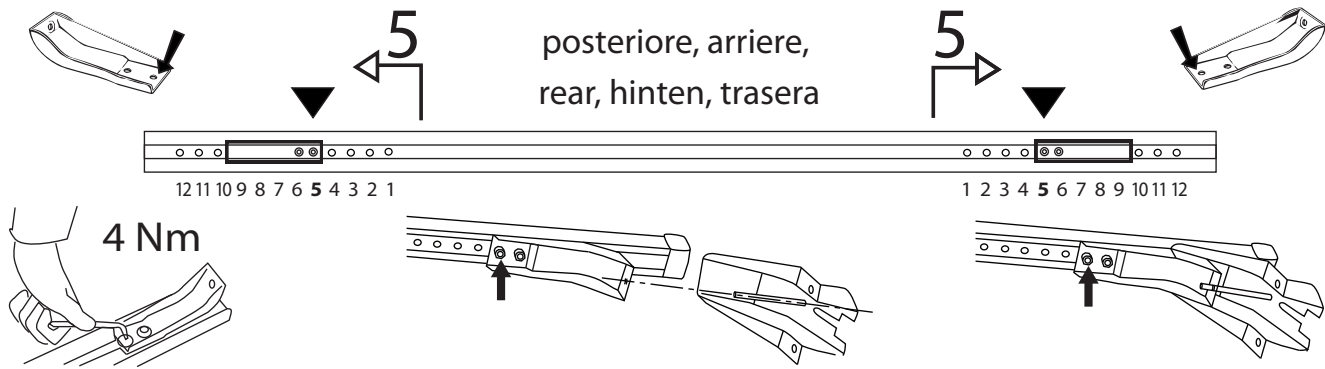

I-sez. tetto vettura
 GB-roof section
 E-seccion del techo

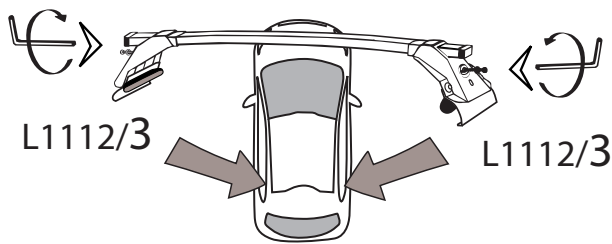
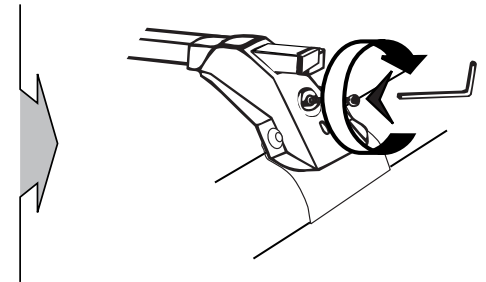

I-sez. tetto vettura
 GB-roof section
 E-seccion del techo

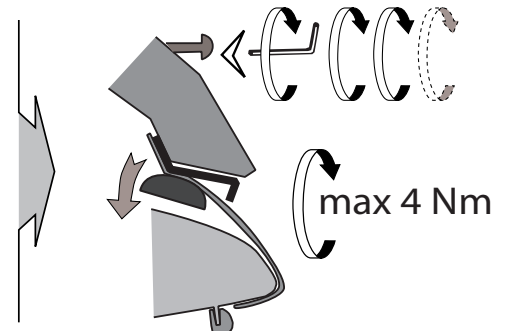

I - Per stringere, usare la chiave come indicato nel disegno. (Non si assumono responsabilità per danni causati dall'impiego di chiavi diverse da quella in dotazione al prodotto).

GB - To tighten please use the wrench as per the drawing.

D - Zum Anziehen benutzen Sie bitte den Inbusschlüssel, nur wie auf dem Bild dargestellt.

F - Pour serrer, utiliser la clé comme indique ci dessous.

E - Para el correcto ajuste, utilizar la llave fija tal y como se indica en la imagen

