









CHEVROLET MATIZ 5 porte 2005

MOSKAT 036

MOSRR0AC010 cm 110

MOSRR0AL006 cm 110

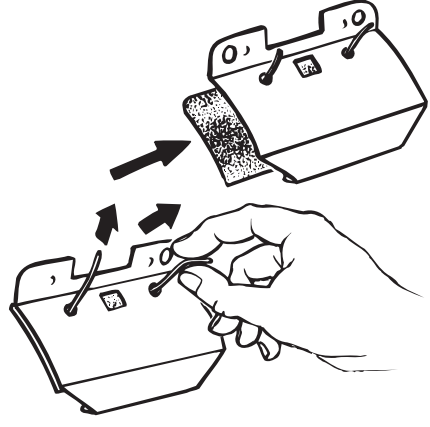
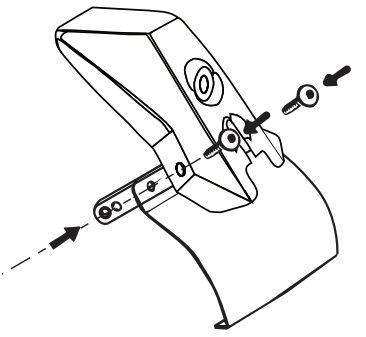
<p>componenti:</p> <ul style="list-style-type: none"> 1 - L1054/1 anteriore (sx)  1 - L1054/2 anteriore (dx)  2 - RC1500/30  1 - L886/1 posteriore (dx)  1 - L886/2 posteriore (sx)  2 - RC1500/60  8 - RCVM6X9Q  4 - RC20200026  1 - RCBR5  	<p>I-montare le guarnizioni GB-fit the gaskets E- montar las juntas</p> 	<p>I-montare gli attacchi GB-fit the clamps E- ajustar las pletinas</p> 
--	--	---

I-montare la barra anteriore
GB- fit the front bar
E- ajustar la barra frontal

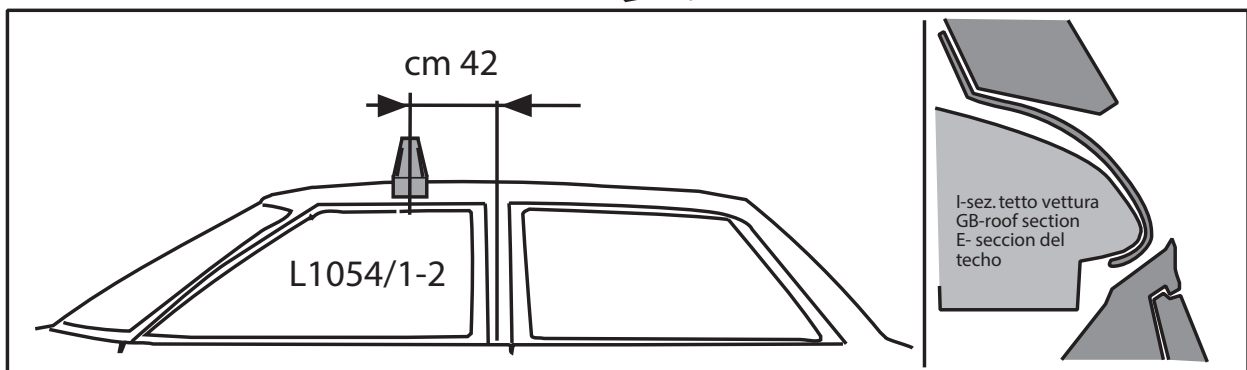
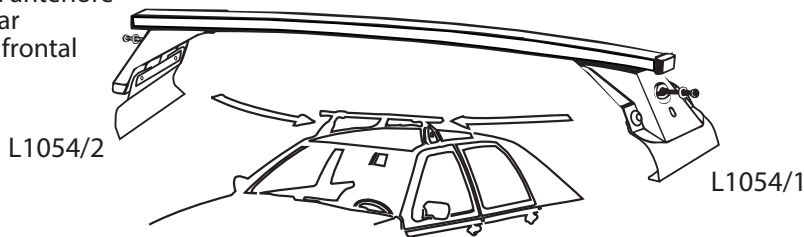

MOSRR0AC010 cm 110

MOSRR0AL006 cm 110

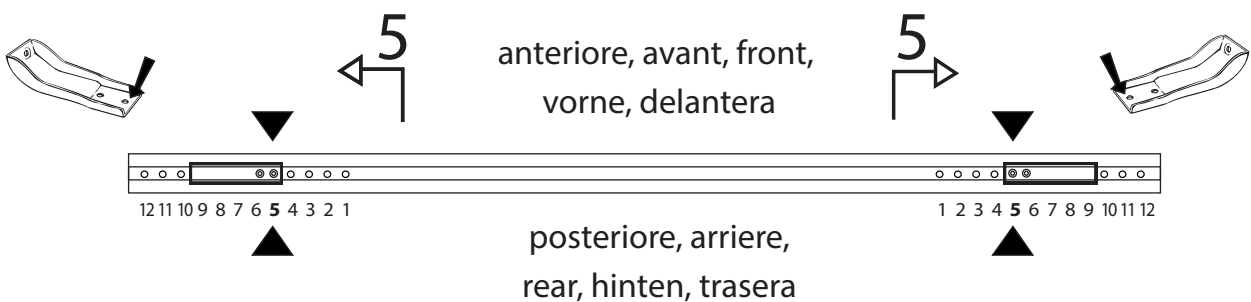

MOCSKT 036

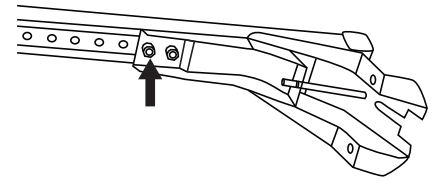
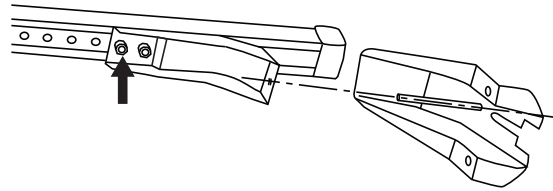
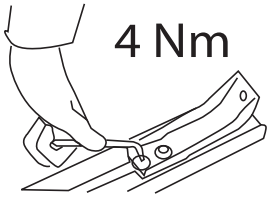

I- montare la barra posteriore
GB-fit the rear bar
E- ajustar la barra trasera

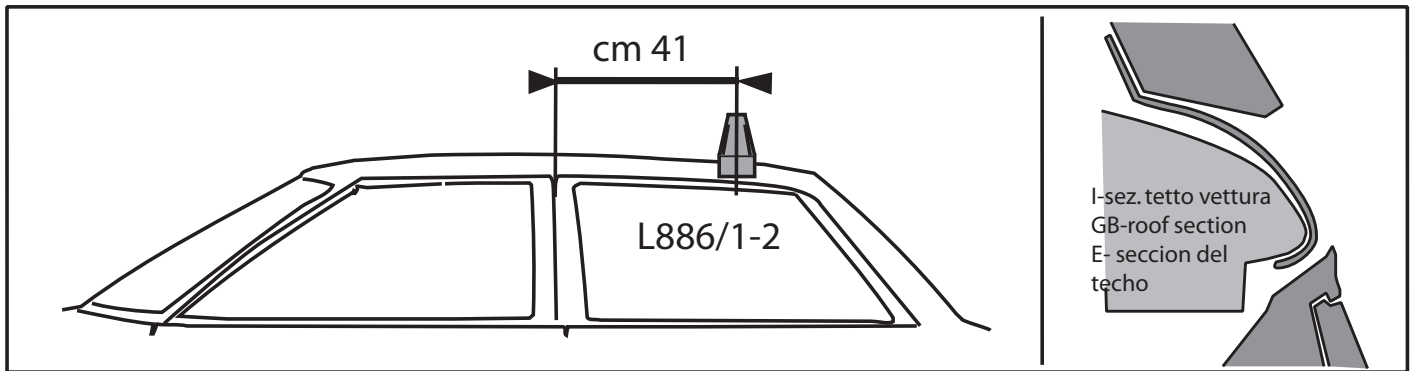
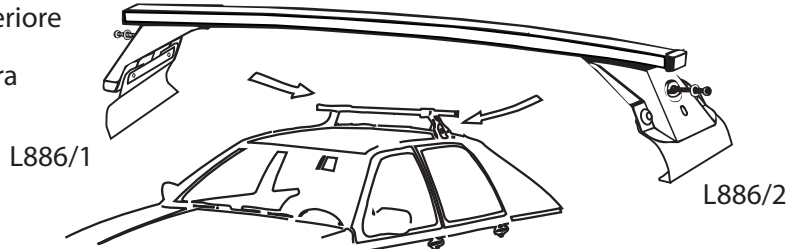

I- Per stringere, usare la chiave come indicato nel disegno. (Non si assumono responsabilità per danni causati dall' impiego di chiavi diverse da quella in dotazione al prodotto).

F- Pour serrer, utiliser la cle comme indique ci dessous.

GB-For tightening, please use the wrench as per the drawing.

D- Zum Anziehen benutzen Sie bitte den Inbusschlüssel, nur wie auf dem Bild dargestellt.

E- Para el correcto ajuste, utilizar la llave fija tal y como se indica en la imagen.

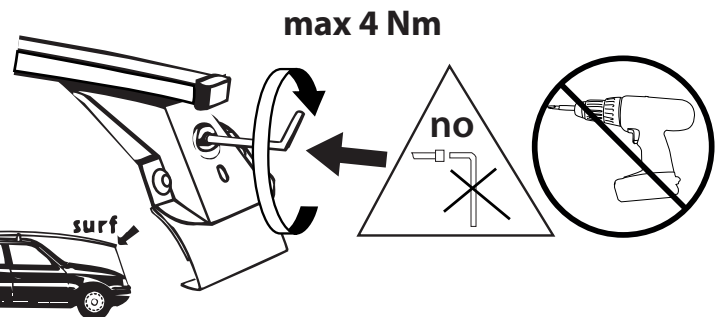
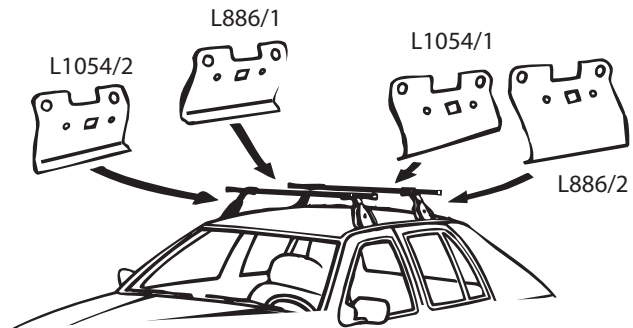

max
Kg. 60

