

MITSUBISHI COLT 5 porte modello 2004

MOC SKT 034

MOC SRR0AC010 cm 110

MOC SRR0AL006 cm 110



2 - L1045 ant.



4 - L1061/4



8 - RCVMX9Q



2 - L1081 post.



4 - L1058/6

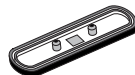

4 - RC20200026



1 - RCBR5

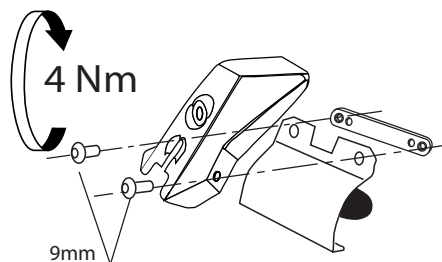
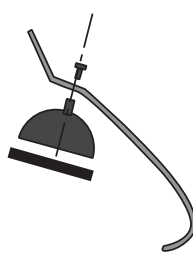
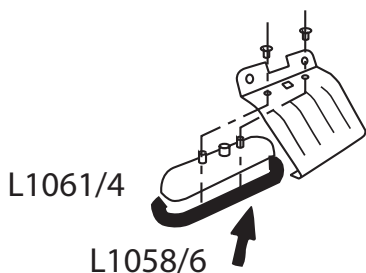

MOC SRR0AC010 cm 110
MOC SRR0AL006 cm 110

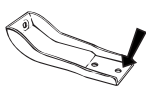

anteriore, avant, front,
vorne, delantera

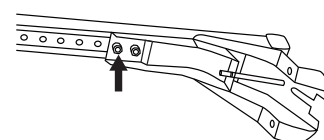
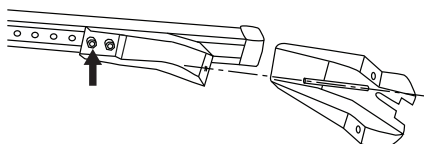
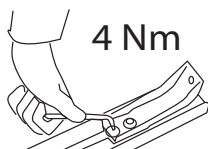
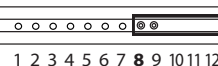
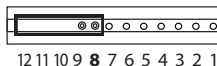
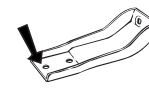

L1045 +
L1061/4

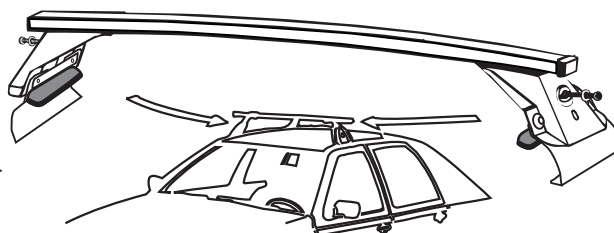

L1045 +
L1061/4

L1045 +
L1061/4

cm 25

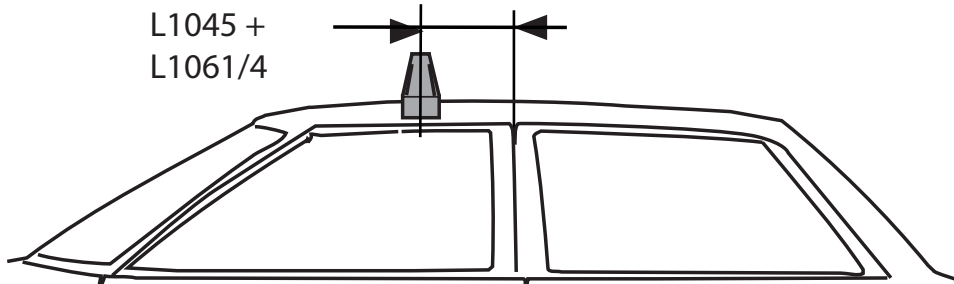

I-sez. tetto vettura
GB-roof section
E- seccion del
techo





MOCSRR0AC010 cm 110

MOCSRR0AL006 cm 110

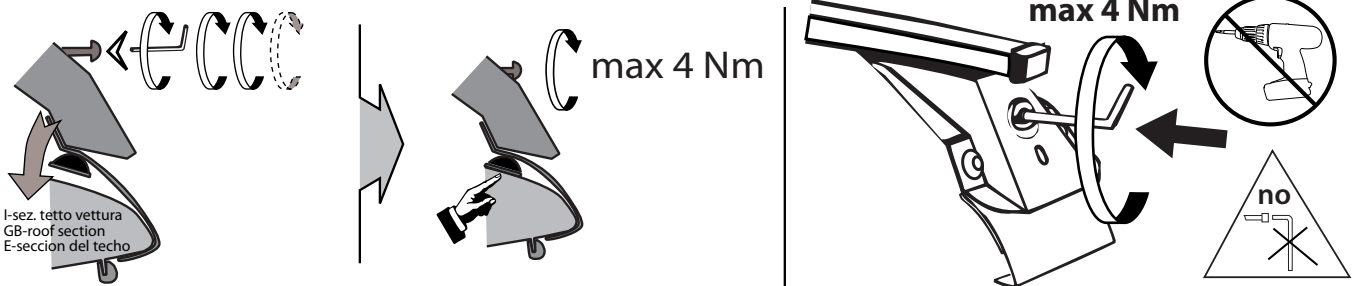
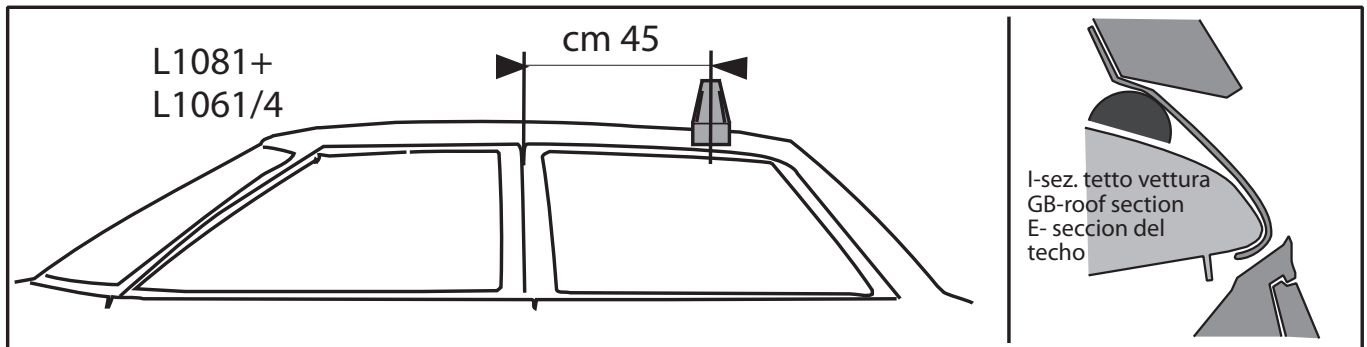
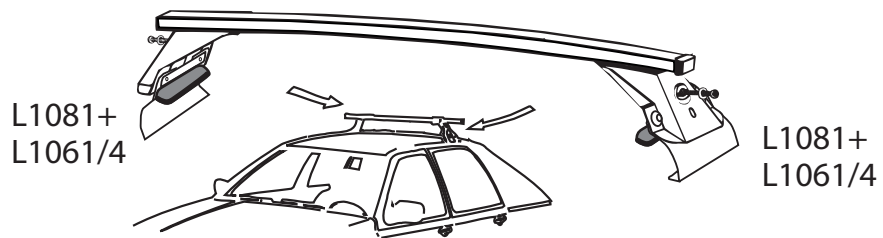
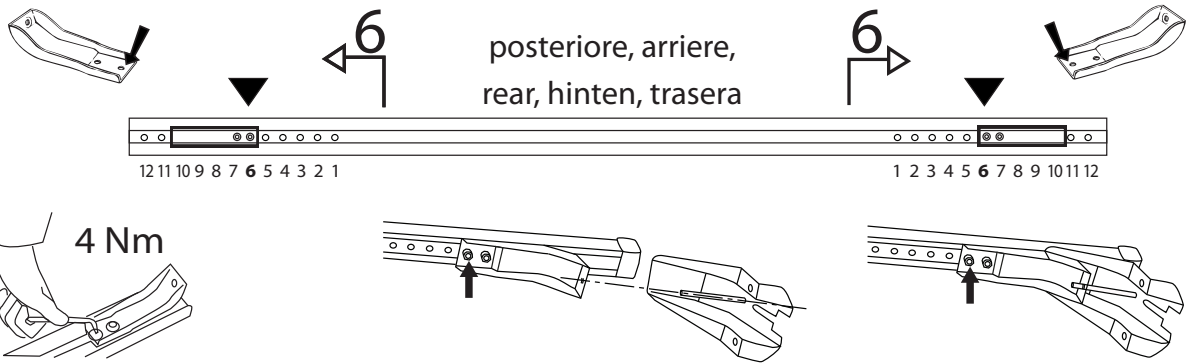

I - Per stringere, usare la chiave come indicato nel disegno. (Non si assumono responsabilità per danni causati dall' impiego di chiavi diverse da quella in dotazione al prodotto).

F - Pour serrer, utiliser la clé comme indique ci dessous.

GB - To tighten please use the wrench as per the drawing.

D - Zum Anziehen benutzen Sie bitte den Inbusschlüssel, nur wie auf dem Bild dargestellt.

E - Para el correcto ajuste, utilizar la llave fija tal y como se indica en la imagen