

BMW serie 5 modello 2003

MOCSKT 011

MOCSRR0AC011 cm 124

MOCSRR0AL007 cm 124

componenti:

1 - L887/1 sx

1 - L887/2 dx

2 - L886/3 posteriore

4 - RC1500/60

8 - RCVM6X9Q

4 - RC20200026

1 - RCBR5

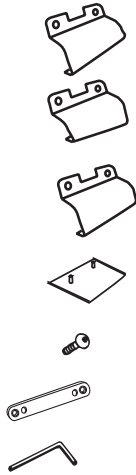

I-montare le guarnizioni
GB-fit the gaskets
E- montar las juntas

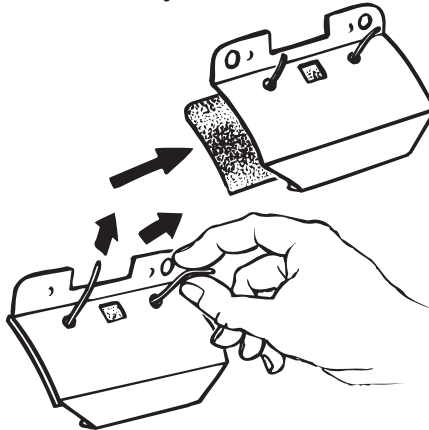

I-montare gli attacchi
GB-fit the clamps
E- ajustar las pletinas

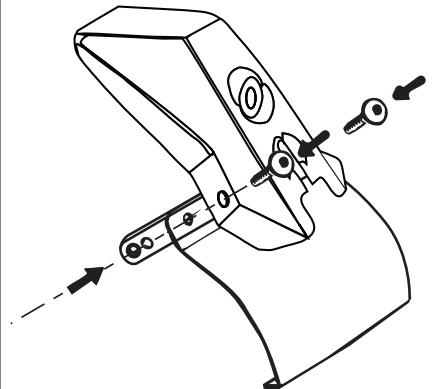

MOCSRR0AC011 cm 124

MOCSRR0AL007 cm 124

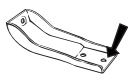

anteriore, avant, front,
vorne, delantera

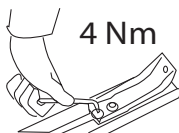
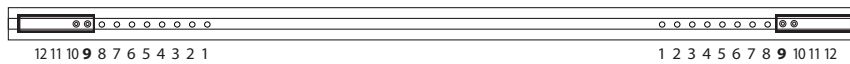
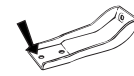

4 Nm

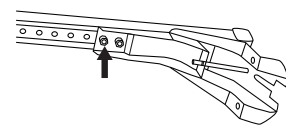
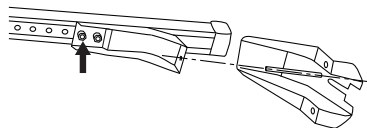

I-montare la barra anteriore
GB- fit the front bar
E- ajustar la barra frontal

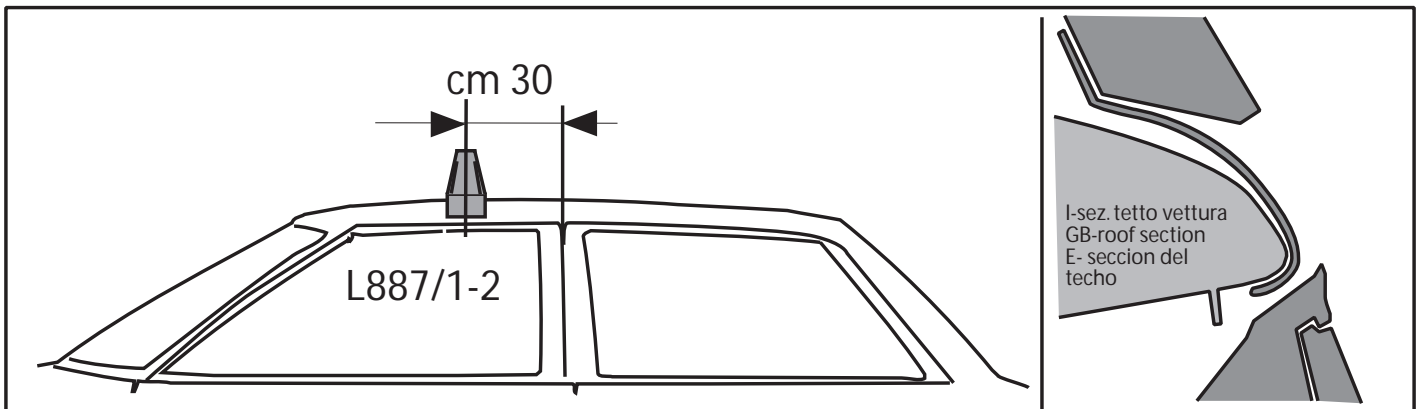
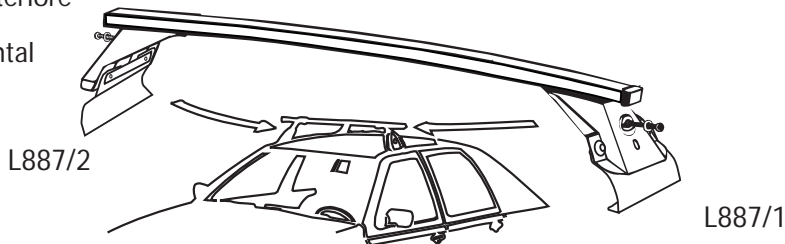



MOCSRR0AC011 cm 124
MOCSRR0AL007 cm 124

MOCSKT 011

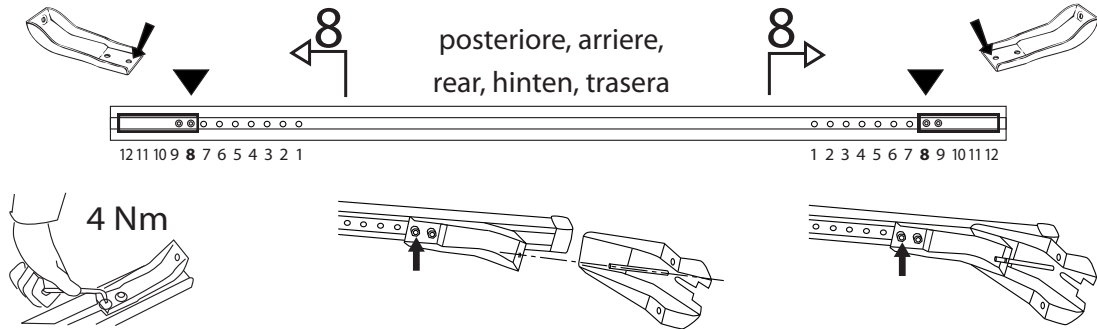

I- montare la bara posteriore
 GB-fit the rear bar
 E- ajustar la barra trasera

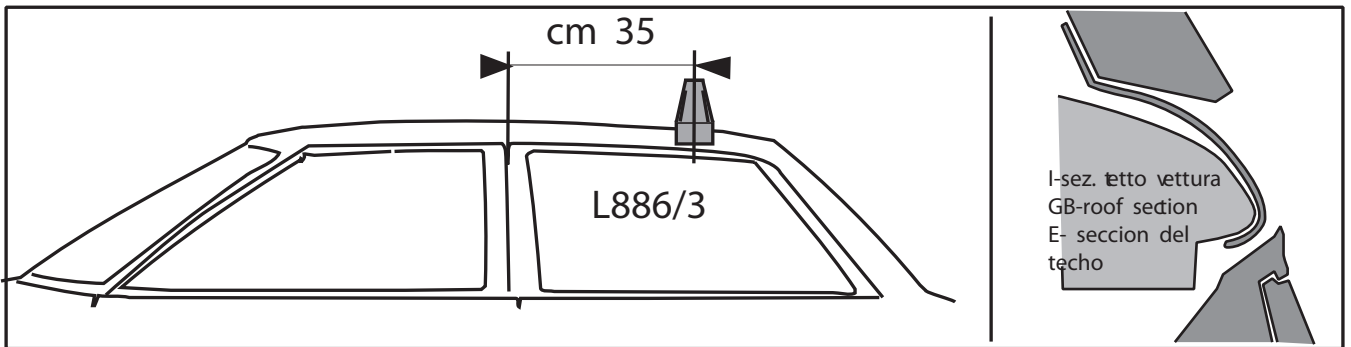
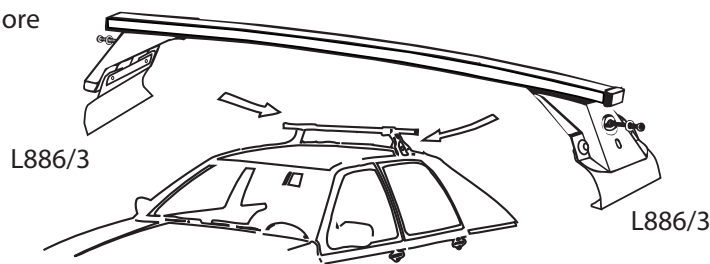

I- Per stringere, usare la chiave come indicato nel disegno. (Non si assumono responsabilità per danni causati dall'impiego di chiavi diverse da quella in dotazione al prodotto).

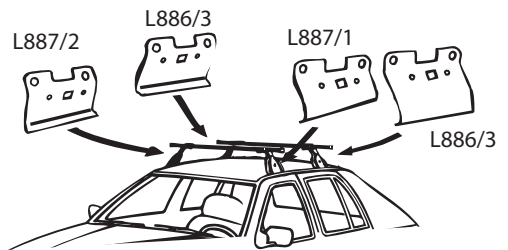

F- Pour serrer, utiliser la cle comme indique ci dessous.
 GB-For tightening, please use the wrench as per the drawing.

D- Zum Anziehen benutzen Sie bitte den Inbusschlüssel, nur wie auf dem Bild dargestellt.

E- Para el correcto ajuste, utilizar la llave fija tal y como se indica en la imagen.

