





DAEWOO KALOS 5 P modello 2002
 CHEVROLET AVEO 5 P modello 2008

MOCSKT 007

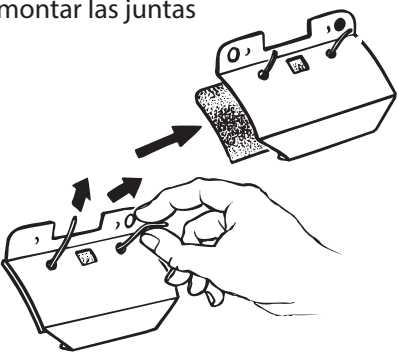
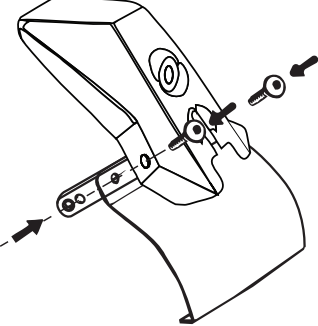

MOCSRR0AC010 cm 110

MOCSRR0AL006 cm 110

<p>componenti:</p> <p>4 - L1043 </p> <p>4 - RC1500/95 </p> <p>8 - RCVM6X9Q </p> <p>4 - RC20200026 </p> <p>1 - RCBR5 </p>	<p>I-montare le guarnizioni GB-fit the gaskets E- montar las juntas</p> 	<p>I-montare gli attacchi GB-fit the clamps E- ajustar las pletinas</p> 
---	--	---

montare la barra anteriore

!!!  **MOCSRR0AC010 cm 110**
MOCSRR0AL006 cm 110

5  anteriore, avant, front, vorne, delantera  5

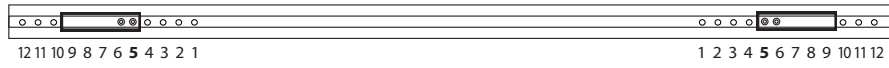

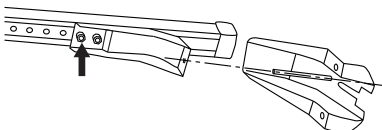
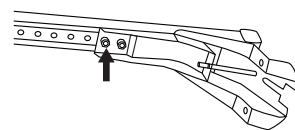
4 Nm   

I-montare la barra anteriore
 GB- fit the front bar
 E- ajustar la barra frontal

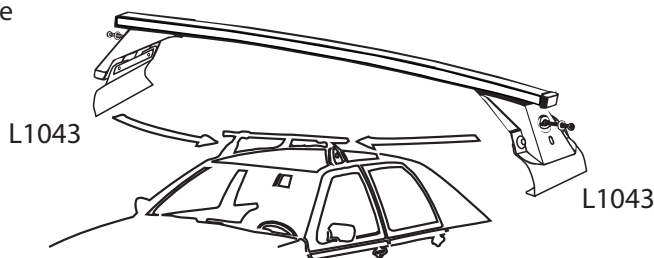
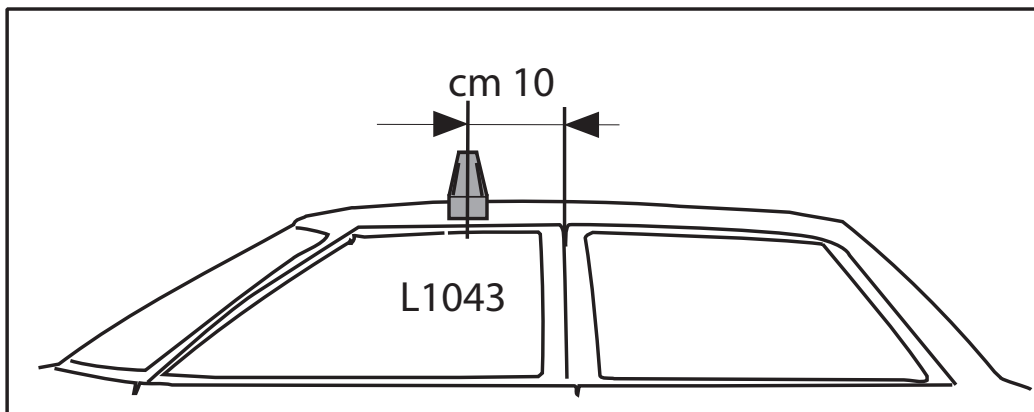
cm 10

L1043



I-sez. tetto vettura
 GB-roof section
 E- seccion del techo

MOCSKT 007

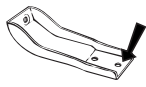

4

posteriore, arriere,
rear, hinten, trasera

4

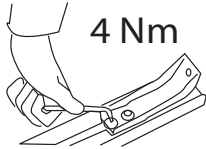
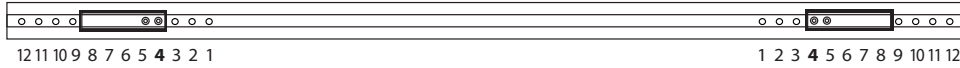
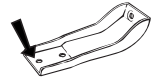

4 Nm

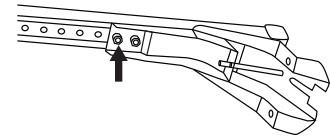
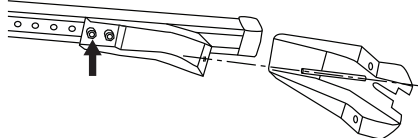

I- montare la barra posteriore
GB-fit the rear bar
E- ajustar la barra trasera

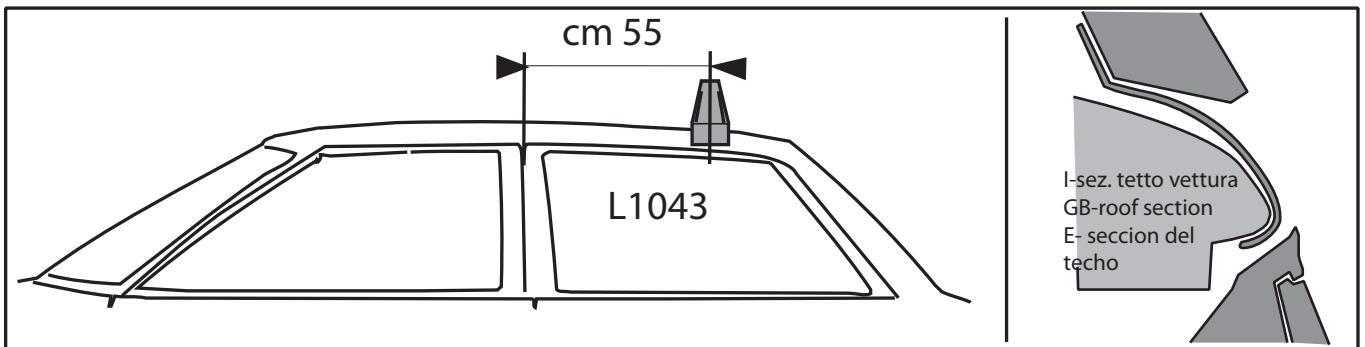
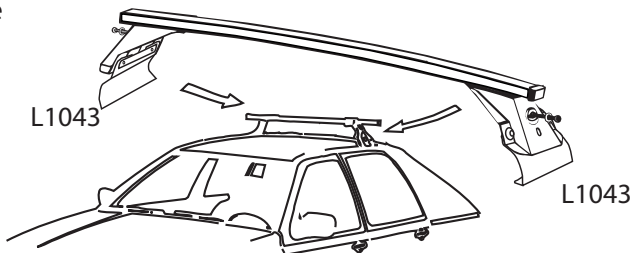

I- Per stringere, usare la chiave come indicato nel disegno. (Non si assumono responsabilità per danni causati dall'impiego di chiavi diverse da quella in dotazione al prodotto).

F- Pour serrer, utiliser la cle comme indique ci dessous.
GB-For tightening, please use the wrench as per the drawing.

D- Zum Anziehen benutzen Sie bitte den Inbusschlüssel, nur wie auf dem Bild dargestellt.

E- Para el correcto ajuste, utilizar la llave fija tal y como se indica en la imagen.

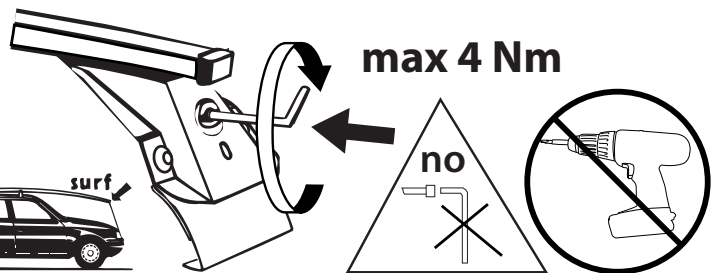
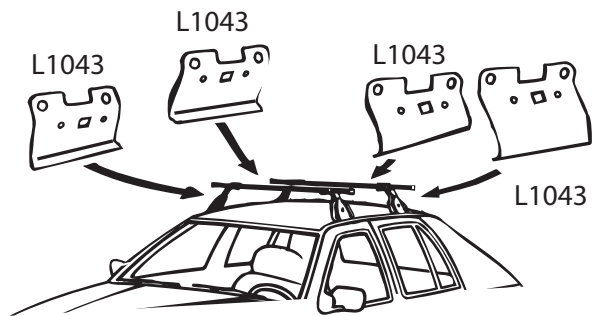

max
Kg. 60

